

Light efficiency:



Light quality:



Color temperature:



Output: 2966 lm

Peak: 1565 cd

Power: 32,3 W

PF: 0,96



Tracking number: [VT240926-000215](#)

Product name:  
**273702-3000K**

Item number:  
**273702-3000K**

Date and time:  
**26-9-2024 11:19:52**

Description:  
**SIDE-LIT LED PANEEL | DESDE |  
150X18CM | 32W | CCT-SWITCH**

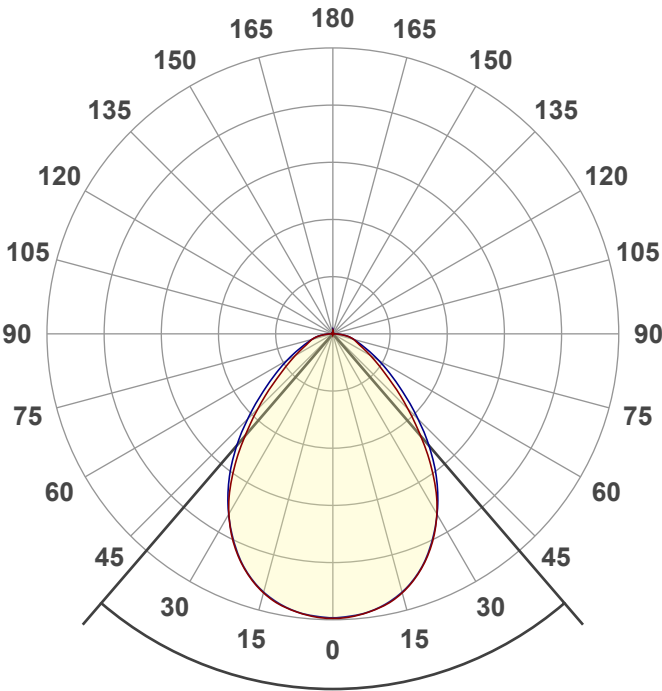

Beam angle **81,4°**



CIE 1931  
x: 0,437  
y: 0,404

Spectra

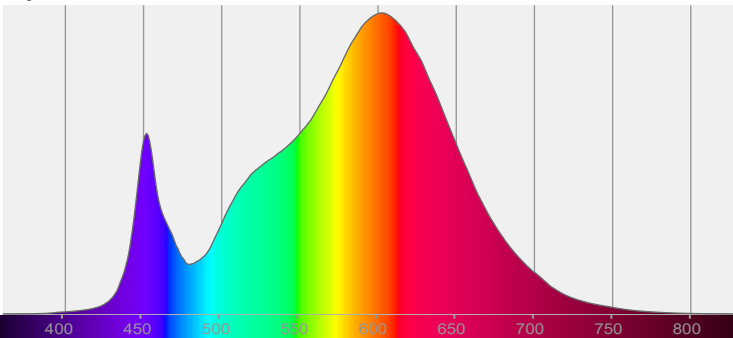

Power

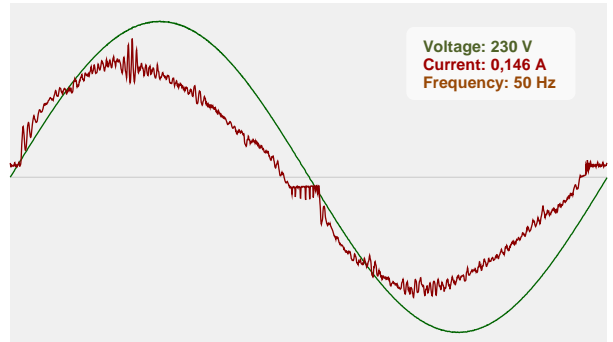

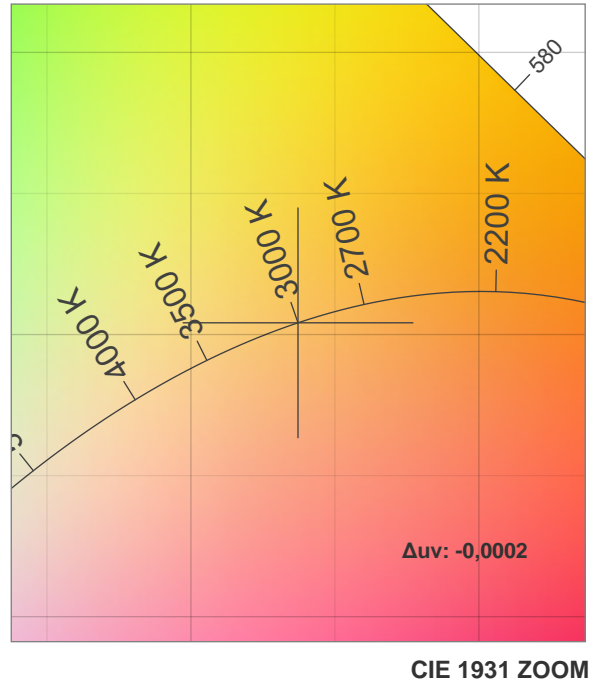
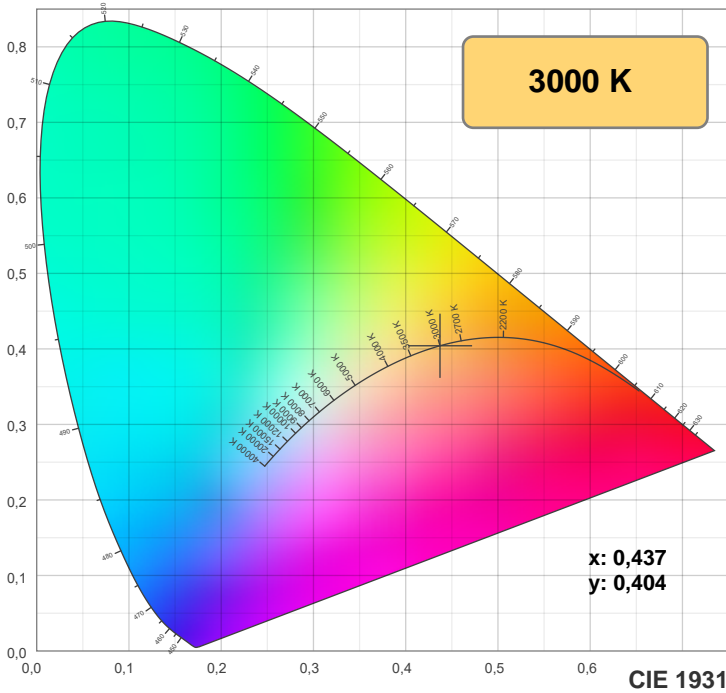

**TM-30: 84,0**

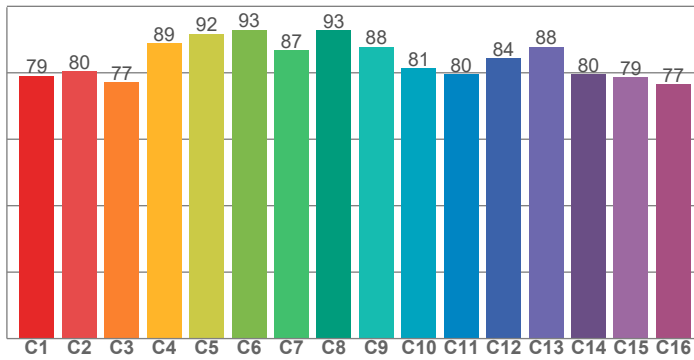

**CRI: 82,0 (R1-R8)**

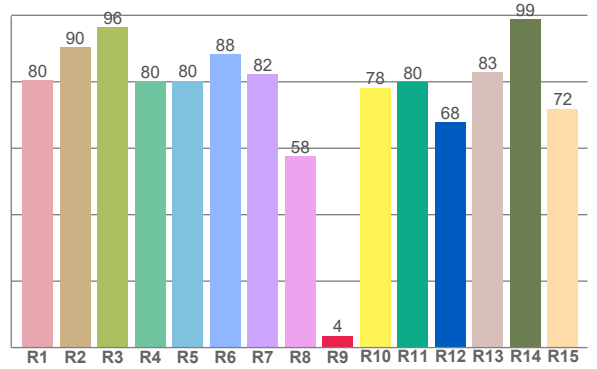

**CQS: 81,2**

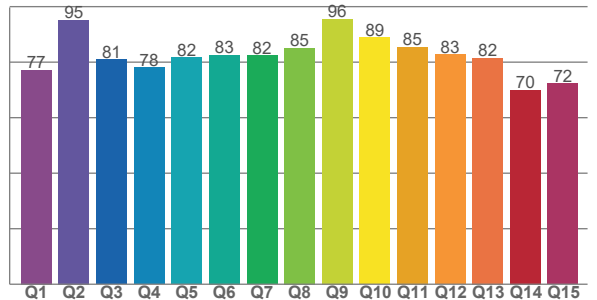

CRI R values, only R1-R8 are used to calculate final CRI value

R1	R2	R3	R4	R5	R6	R7	R8	R9	R10	R11	R12	R13	R14	R15
80,4	90,4	96,4	80,2	80,4	88,3	82,3	57,7	3,6	78,2	79,9	67,7	82,9	98,7	71,9

TM30 C values, 16 binned values out of total of 99 C values

C1	C2	C3	C4	C5	C6	C7	C8	C9	C10	C11	C12	C13	C14	C15	C16
79,0	80,4	77,2	88,8	91,7	92,9	86,7	92,8	87,8	81,3	79,6	84,3	87,8	79,5	78,6	76,5

CQS Q values

Q1	Q2	Q3	Q4	Q5	Q6	Q7	Q8	Q9	Q10	Q11	Q12	Q13	Q14	Q15
77,1	95,2	81,0	78,0	81,6	82,5	82,4	85,2	95,5	88,9	85,5	82,7	81,5	69,9	72,3

**Color parameters**

Color temperature	Color rendering index	Red component	Color fidelity	Color gamut	Color quality scale	Color coordinate cie 1931	Color coordinate cie 1931	Color coordinate	Color coordinate	Color deviation from black body
CCT	CRI	CRI R9	TM30 Rf	TM30 Rg	CQS	x	y	u	v	Δuv
3000 K	82,0	3,6	84,0	95,8	81,2	0,437	0,404	0,251	0,348	-0,0002

**Rf 84,0**  
Fidelity index Rf

**Rg 95,8**  
Gamut index Rg

Hue Bin	R <sub>f</sub>	Shifts (%)	
		Chroma	Hue
1	79	-12%	0%
2	80	-9%	7%
3	77	-3%	12%
4	89	1%	7%
5	92	1%	4%
6	93	3%	-3%
7	87	-4%	-7%
8	93	-4%	-1%
9	88	-6%	4%
10	81	-5%	11%
11	80	0%	15%
12	84	7%	4%
13	88	5%	-7%
14	80	6%	-16%
15	79	-3%	-14%
16	77	-8%	-17%

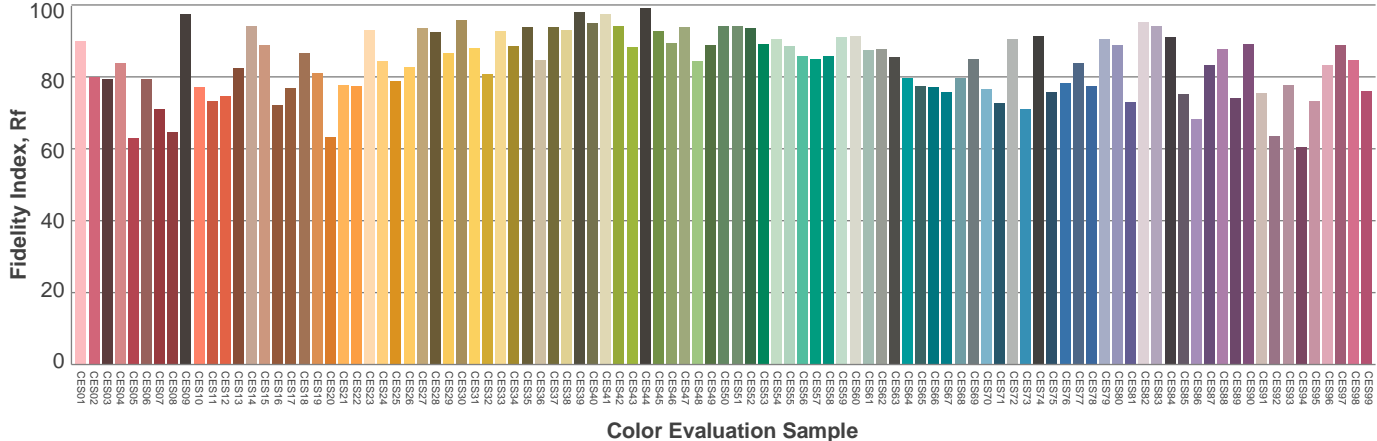
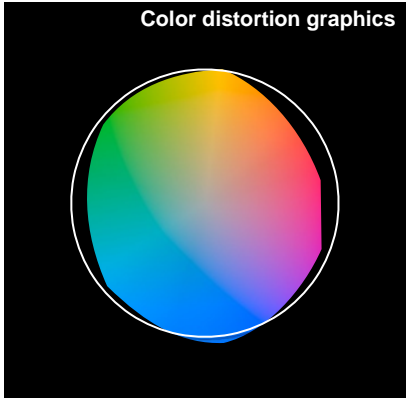
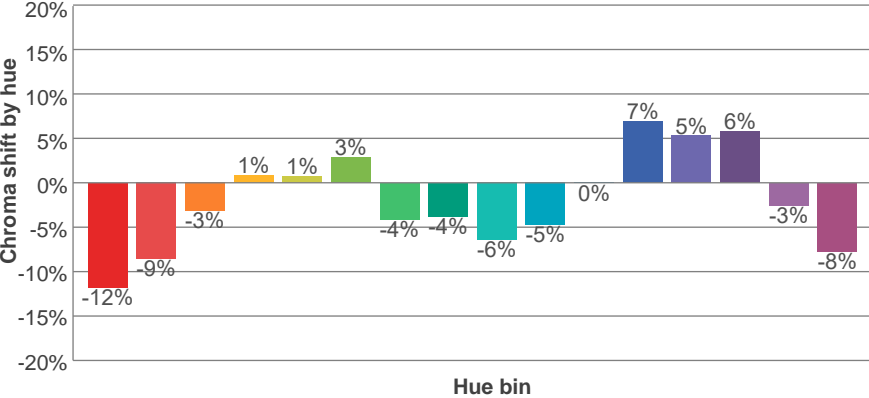
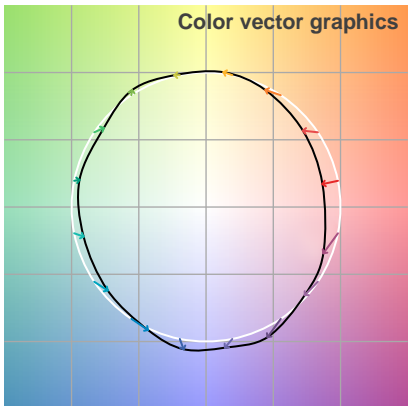
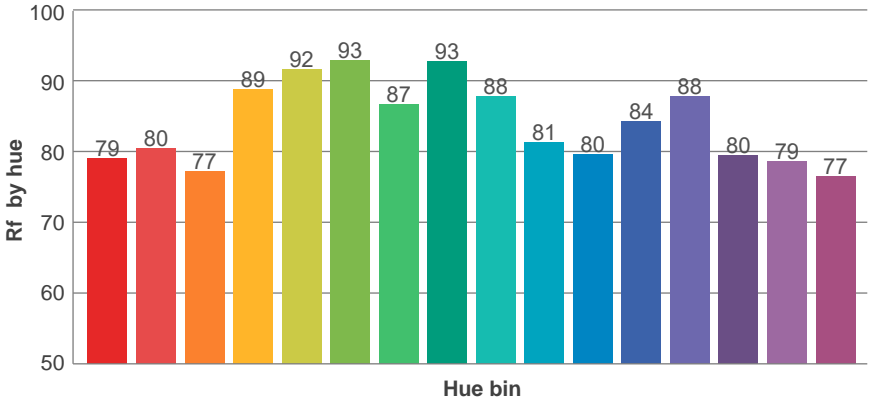
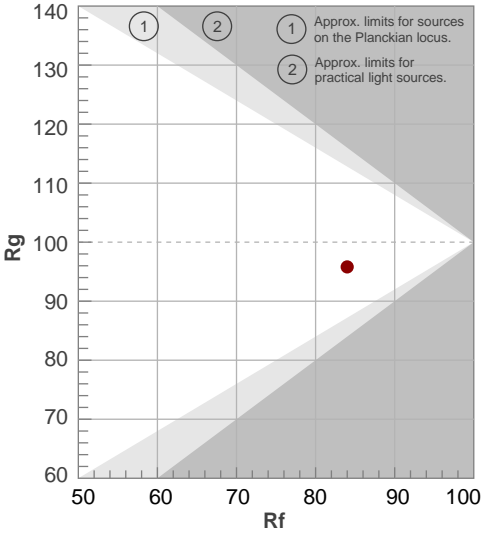

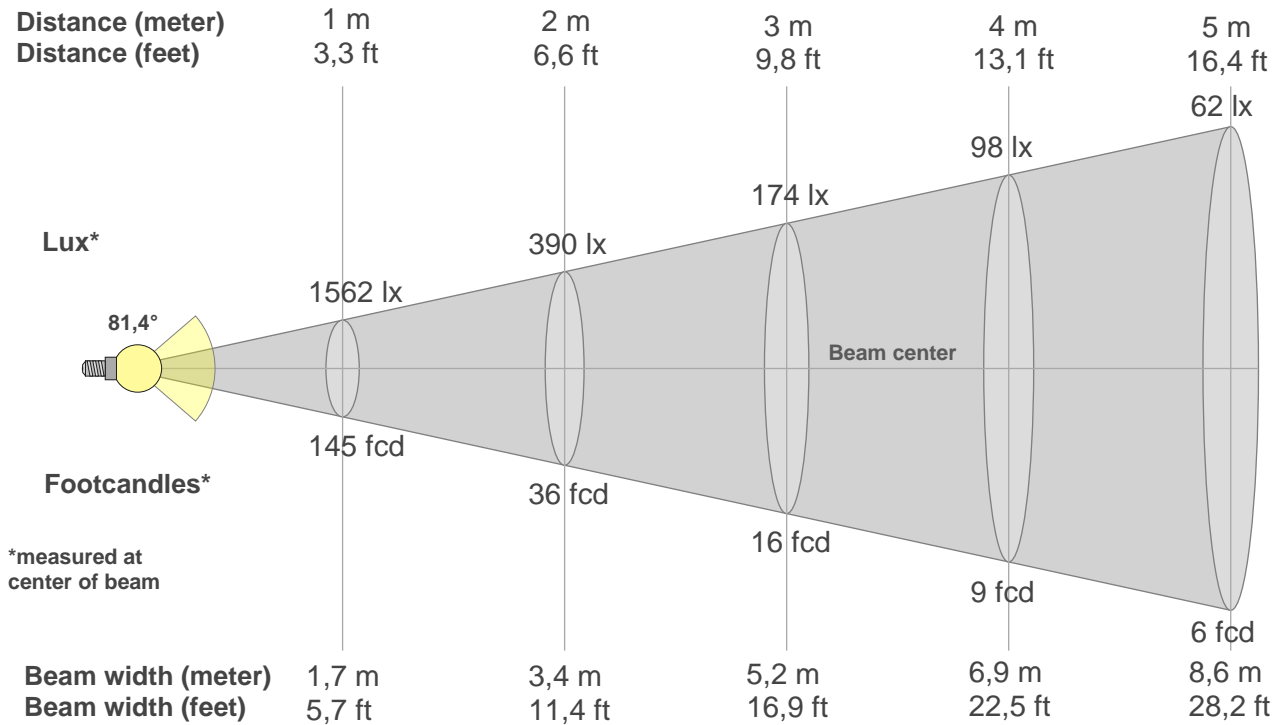

**Beam intensities from 1-20m**

1m	2m	3m	4m	5m	6m	7m	8m	9m	10m	11m	12m	13m	14m	15m	16m	17m	18m	19m	20m
3,3ft	6,6ft	9,8ft	13,1ft	16,4ft	19,7ft	23ft	26,2ft	29,5ft	32,8ft	36,1ft	39,4ft	42,7ft	45,9ft	49,2ft	52,5ft	55,8ft	59,1ft	62,3ft	65,6ft
1562lx	390lx	174lx	98lx	62lx	43lx	32lx	24lx	19lx	16lx	13lx	11lx	9lx	8lx	7lx	6lx	5lx	5lx	4lx	4lx
145,1fcd	36,3fcd	16,1fcd	9,1fcd	5,8fcd	4fcd	3fcd	2,3fcd	1,8fcd	1,5fcd	1,2fcd	1fcd	0,9fcd	0,7fcd	0,6fcd	0,6fcd	0,5fcd	0,4fcd	0,4fcd	0,4fcd

**Intensities in 0° c-plane**

0°	5°	10°	15°	20°	25°	30°	35°	40°	45°	50°	55°	60°	65°	70°	75°	80°	85°	90°	95°
1562	1551	1522	1470	1388	1278	1139	965	770	588	435	321	240	182	144	118	86	46	15	4
100%	99%	97%	94%	89%	82%	73%	62%	49%	38%	28%	21%	15%	12%	9%	8%	6%	3%	1%	0%

**Intensities in 90° c-plane**

0°	5°	10°	15°	20°	25°	30°	35°	40°	45°	50°	55°	60°	65°	70°	75°	80°	85°	90°	95°
1562	1548	1519	1466	1385	1274	1143	996	833	664	511	389	292	215	159	120	87	47	16	5
100%	99%	97%	94%	89%	82%	73%	64%	53%	43%	33%	25%	19%	14%	10%	8%	6%	3%	1%	0%

**Intensities in 180° c-plane**

0°	5°	10°	15°	20°	25°	30°	35°	40°	45°	50°	55°	60°	65°	70°	75°	80°	85°	90°	95°
1562	1551	1522	1470	1388	1278	1139	965	770	588	435	321	240	182	144	118	86	46	15	4
100%	99%	97%	94%	89%	82%	73%	62%	49%	38%	28%	21%	15%	12%	9%	8%	6%	3%	1%	0%

**Intensities in 270° c-plane**

0°	5°	10°	15°	20°	25°	30°	35°	40°	45°	50°	55°	60°	65°	70°	75°	80°	85°	90°	95°
1562	1548	1519	1466	1385	1274	1143	996	833	664	511	389	292	215	159	120	87	47	16	5
100%	99%	97%	94%	89%	82%	73%	64%	53%	43%	33%	25%	19%	14%	10%	8%	6%	3%	1%	0%

Beam angle 50%	Field angle 10%	Cutoff angle 2,5%	Intensity ratio in 120° cone	Intensity ratio in 90° cone
<b>81,4°</b>	<b>139°</b>	<b>171,7°</b>	<b>86,3%</b>	<b>68,2%</b>

**iso-candela diagram**

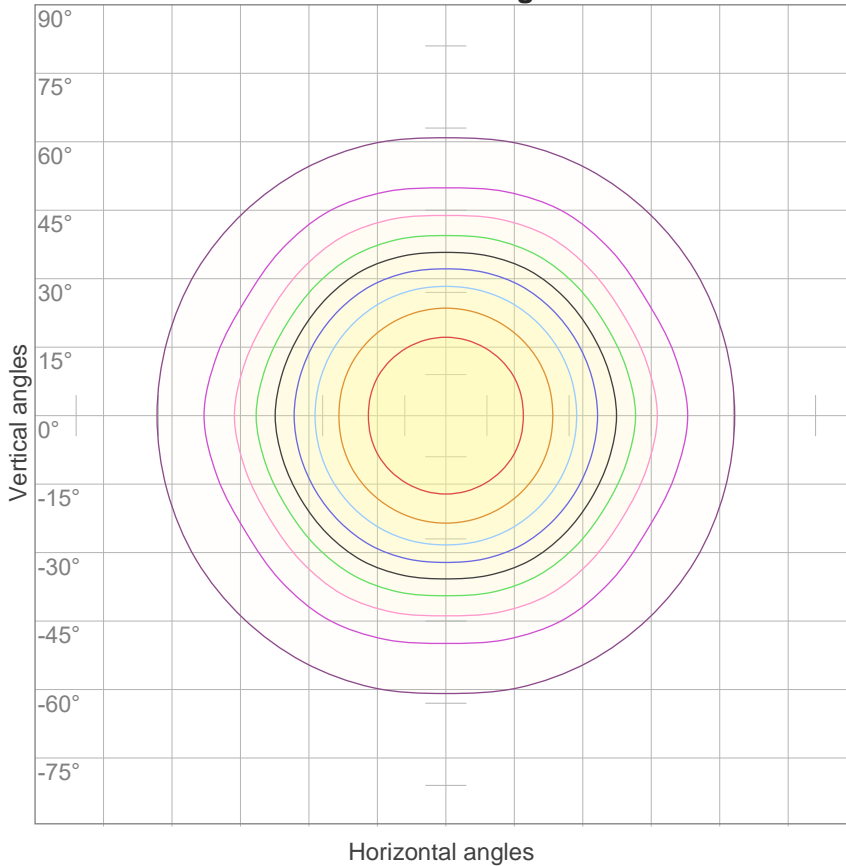

10%	156 cd
20%	312 cd
30%	469 cd
40%	625 cd
50%	781 cd
60%	937 cd
70%	1093 cd
80%	1249 cd
90%	1406 cd

Conditions:

Number of c-planes: 12

Candela at center: 1562 cd

**iso-lux diagram**

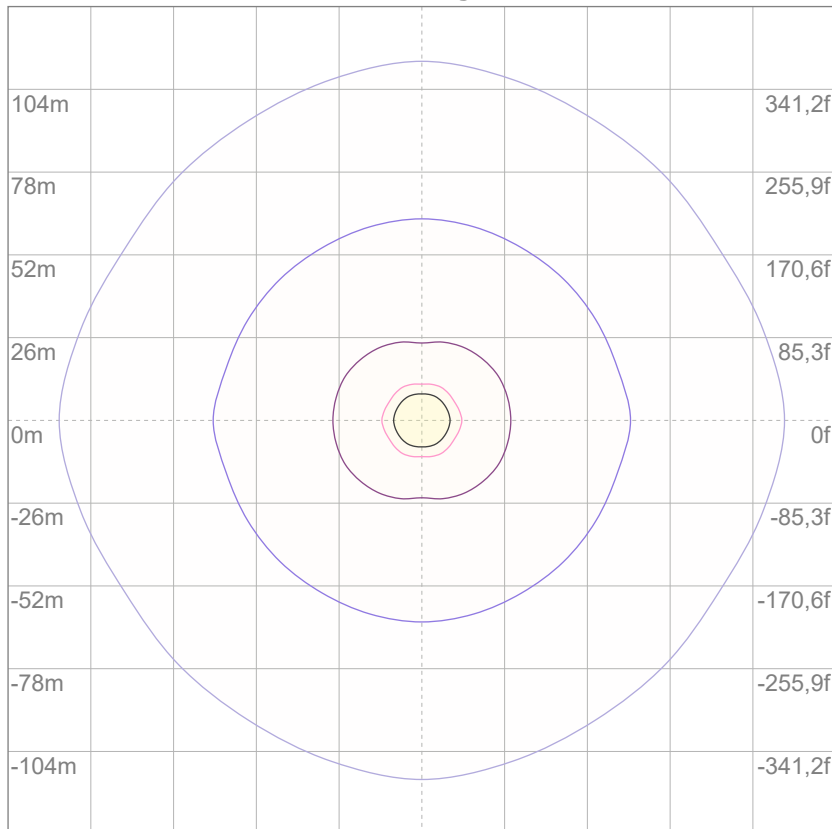

3%	0,469 lx
5%	0,781 lx
10%	1,56 lx
30%	4,69 lx
50%	7,81 lx

Conditions:

Number of c-planes: 12

Lux at center: 15,6 lx

*Lux distribution on a surface when lamp is mounted at 10 meters from the surface.*

Mounting height: 10 meters (33 feet)

**Glare evaluation according to UGR**

p Ceiling	70	70	50	50	30	70	70	50	50	30	
p Walls	50	30	50	30	30	50	30	50	30	30	
p Floor	20	20	20	20	20	20	20	20	20	20	
Room size X Y	Viewing direction at right angles to lamp axis					Viewing direction parallel to lamp axis					
2H	2H	14,6	15,6	14,8	15,9	16,1	14,8	15,8	15,0	16,1	16,3
	3H	15,3	16,4	15,7	16,7	16,9	15,6	16,7	16,0	16,9	17,2
	4H	15,9	16,9	16,3	17,2	17,4	16,0	17,1	16,5	17,4	17,6
	6H	16,5	17,4	16,8	17,7	18,0	16,5	17,4	16,8	17,7	18,1
	8H	16,7	17,5	17,0	17,9	18,3	16,7	17,6	17,0	17,9	18,3
12H	16,8	17,7	17,2	18,1	18,5	16,8	17,6	17,2	18,0	18,5	
4H	2H	14,8	15,9	15,2	16,1	16,4	15,0	16,0	15,4	16,3	16,6
	3H	16,0	16,8	16,4	17,2	17,6	16,2	17,0	16,6	17,4	17,9
	4H	16,6	17,4	17,1	17,8	18,4	16,7	17,5	17,2	17,9	18,5
	6H	17,3	18,1	17,8	18,4	18,8	17,3	18,1	17,8	18,4	18,8
	8H	17,6	18,3	18,1	18,7	19,1	17,5	18,2	18,1	18,6	19,0
12H	17,8	18,4	18,4	18,9	19,3	17,7	18,3	18,2	18,7	19,2	
8H	4H	16,9	17,6	17,4	17,9	18,3	17,0	17,7	17,5	18,0	18,4
	6H	17,8	18,3	18,3	18,7	19,3	17,7	18,2	18,2	18,7	19,3
	8H	18,2	18,6	18,7	19,2	19,8	18,1	18,5	18,6	19,1	19,7
	12H	18,5	18,9	19,1	19,4	20,0	18,3	18,7	18,9	19,2	19,9
12H	4H	16,9	17,5	17,4	17,9	18,4	17,0	17,6	17,5	18,0	18,5
	6H	17,9	18,3	18,4	18,8	19,5	17,8	18,3	18,4	18,8	19,5
	8H	18,3	18,7	18,9	19,2	19,8	18,2	18,6	18,8	19,1	19,7
Variation of the observer position for the luminaire distance S											
S = 1.0H	0,2 / -0,3					0,1 / -0,2					
S = 1.5H	0,4 / -0,5					0,5 / -0,5					
S = 2.0H	0,9 / -0,8					1,1 / -0,8					
CIE 117-1995. Corrected glare indices referring to 2966 lm total luminous flux											

**Coefficients of Utilization**

Ceiling reflectance	80				70				50			30			10			0
	70	50	30	10	70	50	30	10	50	30	10	50	30	10	50	30	10	0
Wall reflectance	70	50	30	10	70	50	30	10	50	30	10	50	30	10	50	30	10	0
Floor reflectance	20	20	20	20	20	20	20	20	20	20	20	20	20	20	20	20	20	0
RCR	(RCR: Room Cavity Ratio)																	
	Room Values are expressed as percentage of Lumens delivered to the task surface																	
0	119	119	119	119	116	116	116	116	111	111	111	106	106	106	101	101	101	99
1	110	106	102	99	107	103	100	97	99	96	94	95	93	91	91	90	88	86
2	102	94	88	83	99	92	87	82	89	84	80	85	82	78	82	79	77	74
3	94	85	77	72	91	83	76	71	80	74	70	77	72	68	75	71	67	65
4	87	76	69	63	85	75	68	62	73	66	61	70	65	60	68	63	60	58
5	81	69	61	55	79	68	61	55	66	59	54	64	58	54	62	57	53	51
6	75	63	55	49	73	62	55	49	61	54	49	59	53	48	57	52	48	46
7	70	58	50	45	69	57	50	44	56	49	44	54	48	44	53	47	43	41
8	66	54	46	40	64	53	45	40	51	45	40	50	44	40	49	44	39	38
9	62	50	42	37	60	49	42	37	48	41	37	47	41	36	46	40	36	34
10	58	46	39	34	57	45	38	34	44	38	34	44	38	33	43	37	33	32

LAMPS (number of lamps)

**Luminaire budgetary diagram**

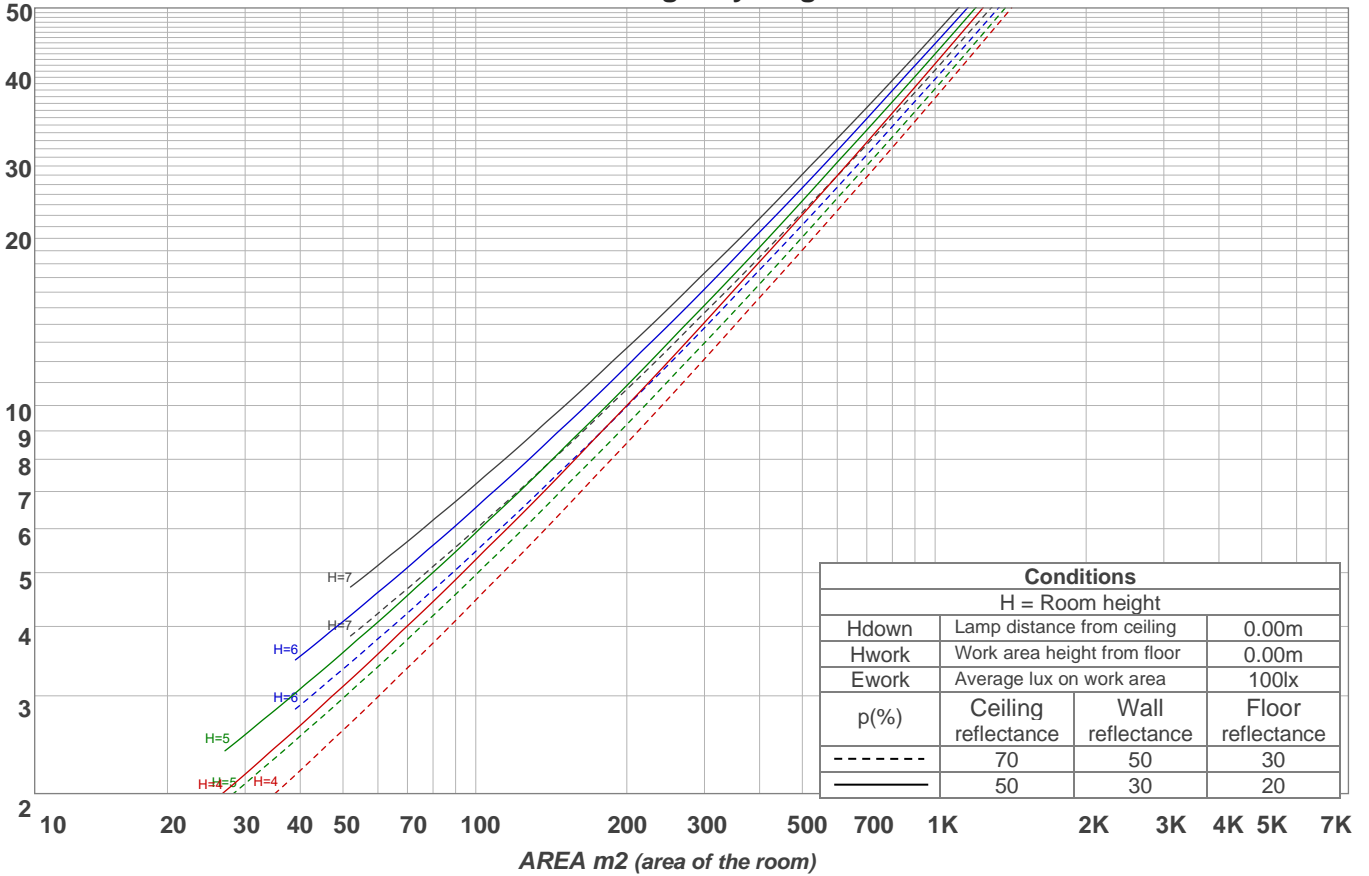

**Zonal Lumen Summary**

0°-10°	10°-20°	20°-30°	30°-40°	40°-50°	50°-60°	60°-70°	70°-80°	80°-90°
{LUM0-10}	413 lm	586 lm	614 lm	482 lm	316 lm	197 lm	127 lm	50,8 lm
90°-100°	100°-110°	110°-120°	120°-130°	130°-140°	140°-150°	150°-160°	160°-170°	170°-180°
5,91 lm	4,44 lm	4,45 lm	4,44 lm	4,15 lm	3,54 lm	2,76 lm	1,82 lm	0,641 lm

LCS table

BUG rating:	B2 U2 G1	
<b>Forward light</b>	Lumens	Lumens %
Low(0-30):	572,8	19,3%
Medium(30-60):	706,2	23,8%
High(60-80):	162,2	5,5%
Very high(80-90):	25,5	0,9%
<b>Back light</b>		
Low(0-30):	572,8	19,3%
Medium(30-60):	706,2	23,8%
High(60-80):	162,2	5,5%
Very high(80-90):	25,5	0,9%
<b>Uplight</b>		
Low(90-100):	6,3	0,2%
High(100-180):	26,2	0,9%

LCS graph

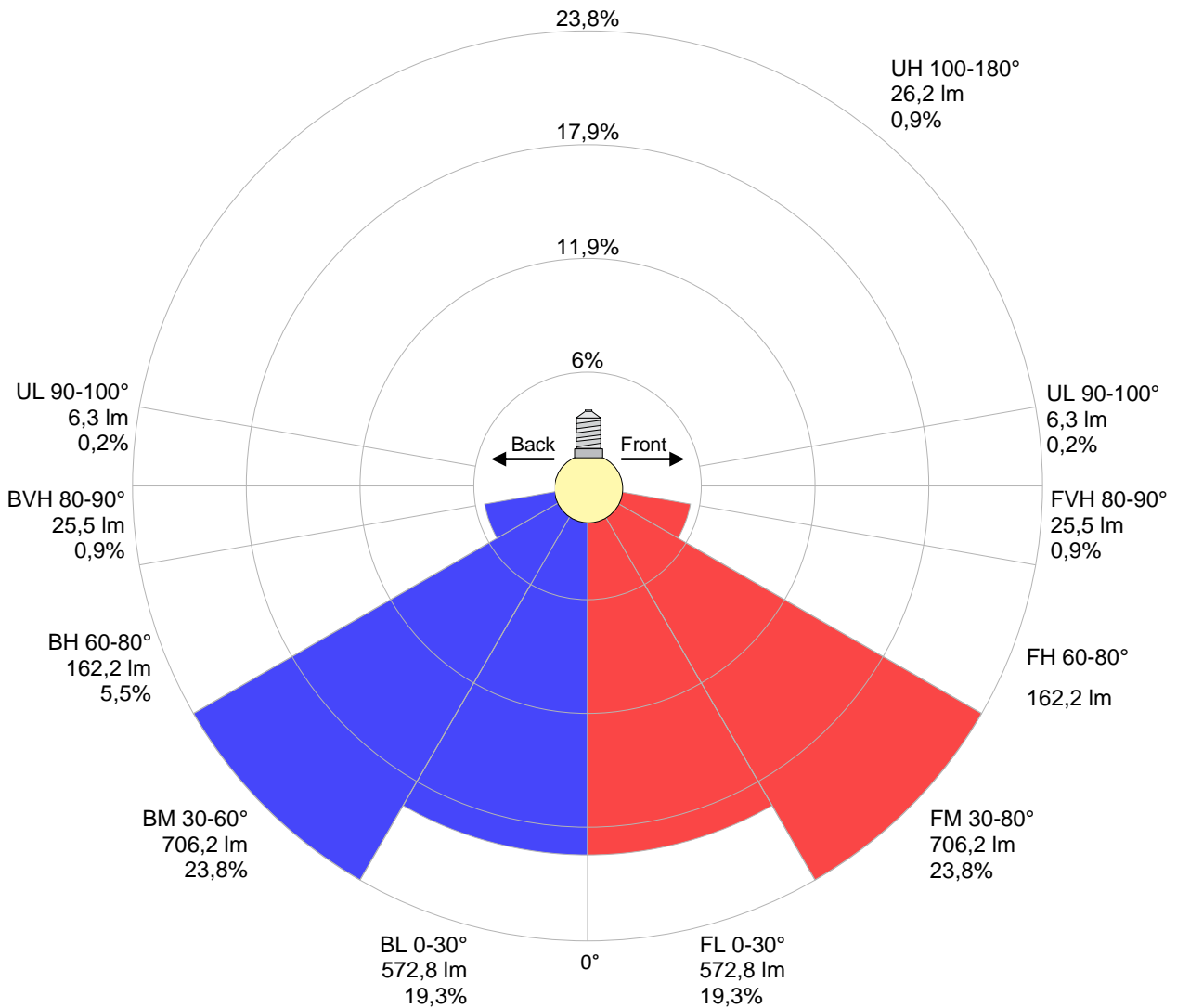

**Warmup curve**

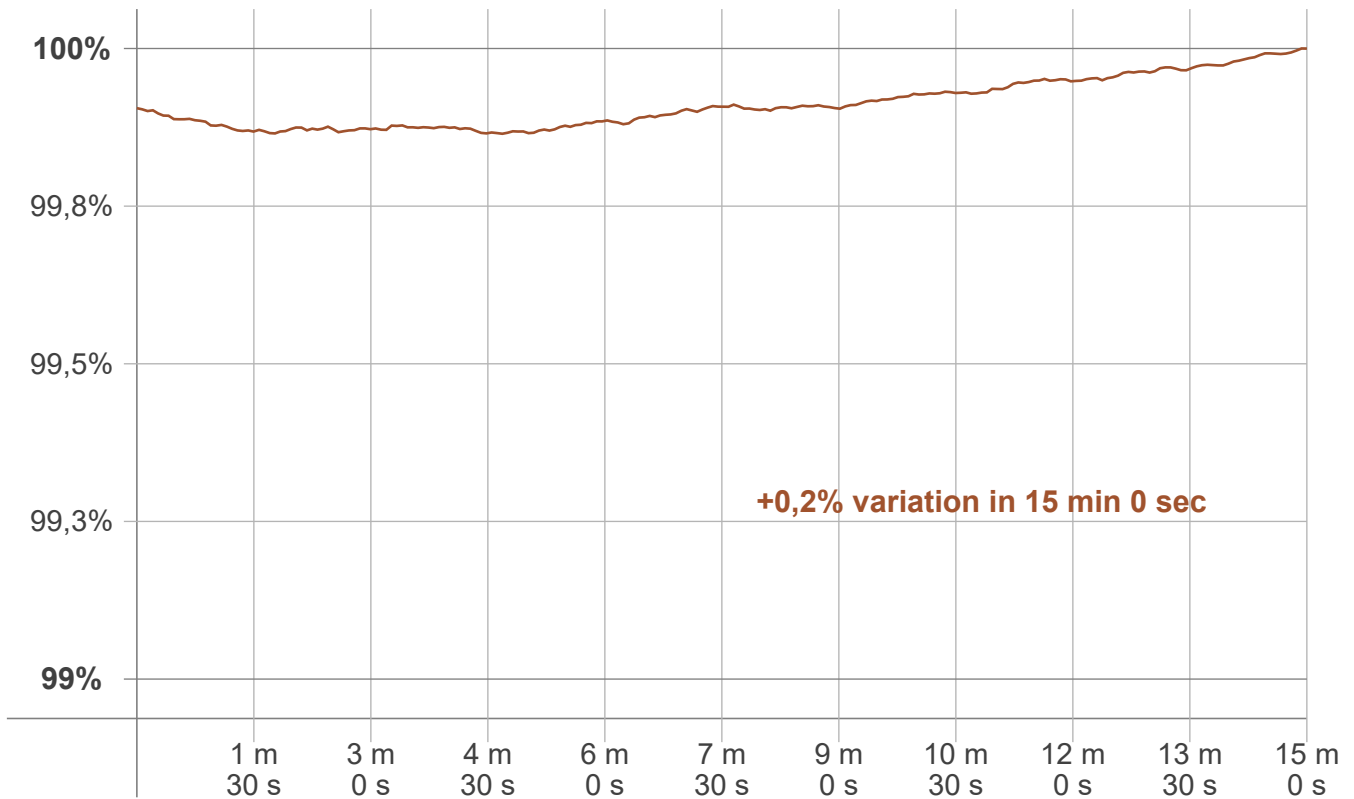

**Warmup result**

<b>Warmup time:</b>	<b>Lamp stabilized in 15 min 0 sec</b>
<b>Warmup variation</b>	<b>+0,2%</b>

**Warmup conditions**

<b>Stable period:</b>	<b>15 min</b>
<b>Stable change max:</b>	<b>2,0%</b>
<b>Minimum time:</b>	<b>15 min</b>

**Color temperature change**

CCT start	CCT change	CCT end
2999 K	+1 K	3000 K

**Output change**

Output start	Output change	Output end
2964 lm	+2 lm	2966 lm

**Flicker curve (complete sampled flicker signal)**



**Flicker frame (frame of one flicker period)**

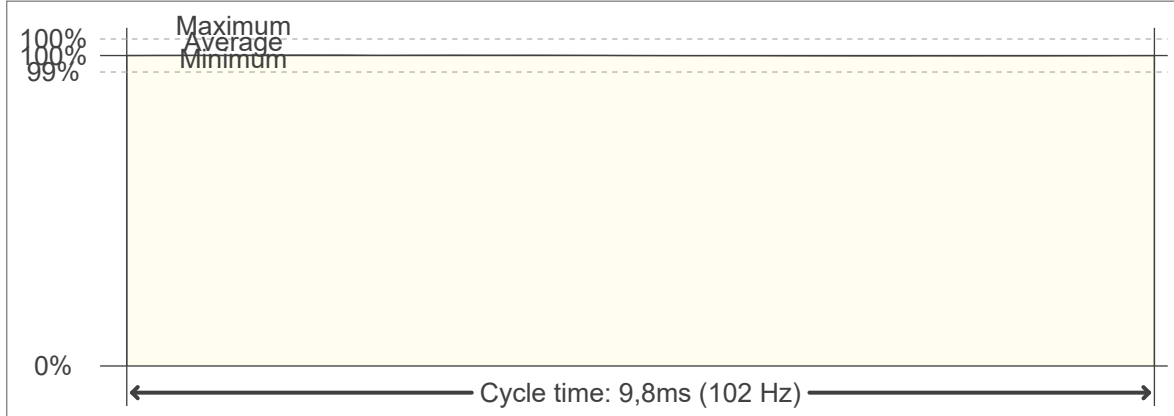

**Flicker FFT (frequency scope of flicker curve)**

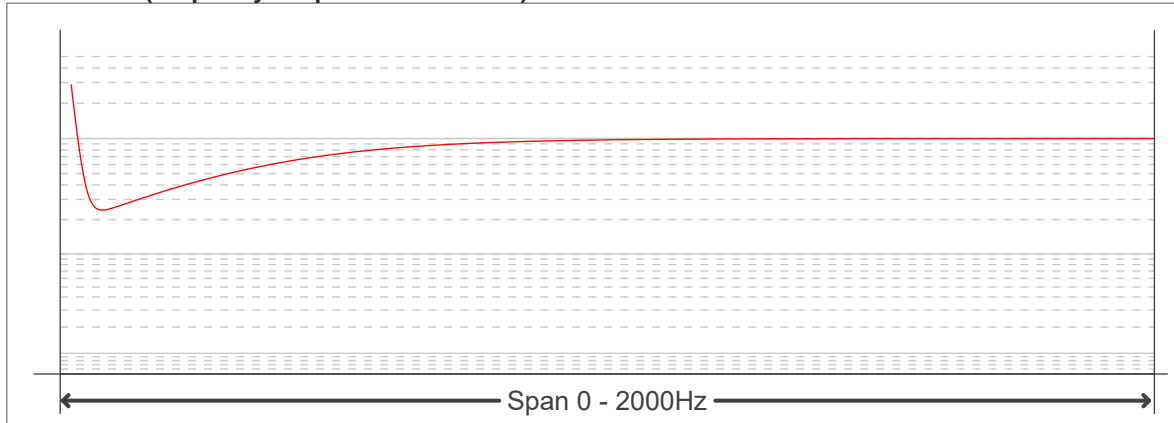

**Flicker results:**

Flicker frequency:		102,04 Hz	
Flicker index:	0	JA8/10 40Hz	0,02 %
Flicker percentage:	0,25 %	JA8/10 90Hz	0,03 %
SVM: (Visual flicker)	0,01	JA8/10 200Hz	0,18 %
PstLM	0,02	JA8/10 400Hz	0,2 %
Mp	0,01	JA8/10 1000Hz	0,23 %

**Flicker conditions:**

Sample rate:	20000 samples/second
--------------	----------------------