

Light efficiency:



Light quality:



Color temperature:



Output: 3482 lm

Peak: 1582 cd

Power: 29,6 W

PF: 0,95



Tracking number: [VT240930-000970](#)

Product name:

277724-3000K

Item number:

277724-3000K

Date and time:

30-9-2024 16:30:24

Description:

BACK-LIT LED PANEEL | EUROPA | 120X30CM | 30W | ZWART | CCT-SWITCH

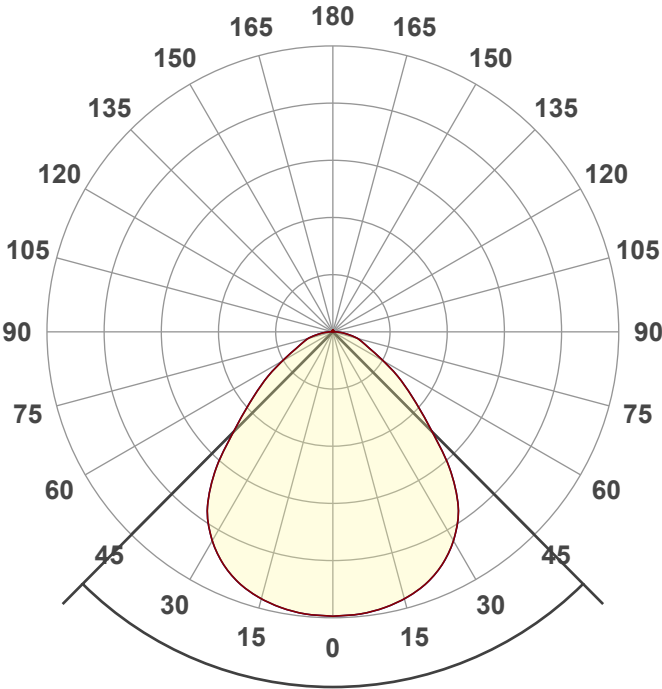

Beam angle **89,6°**



CIE 1931
x: 0,437
y: 0,404

Spectra

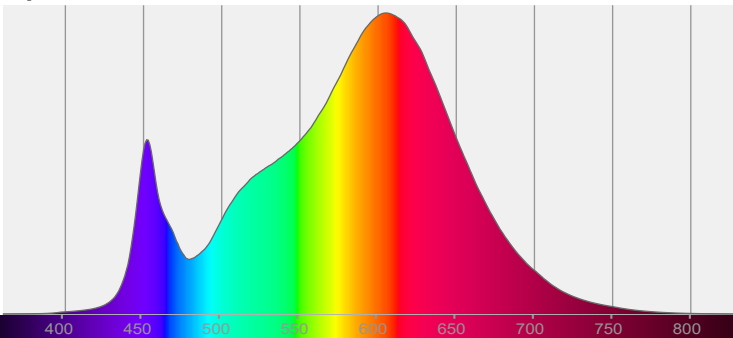

Power

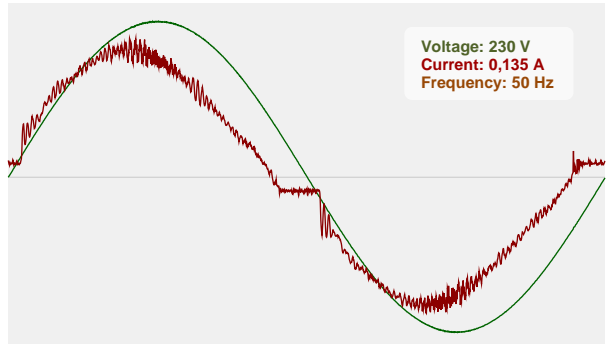

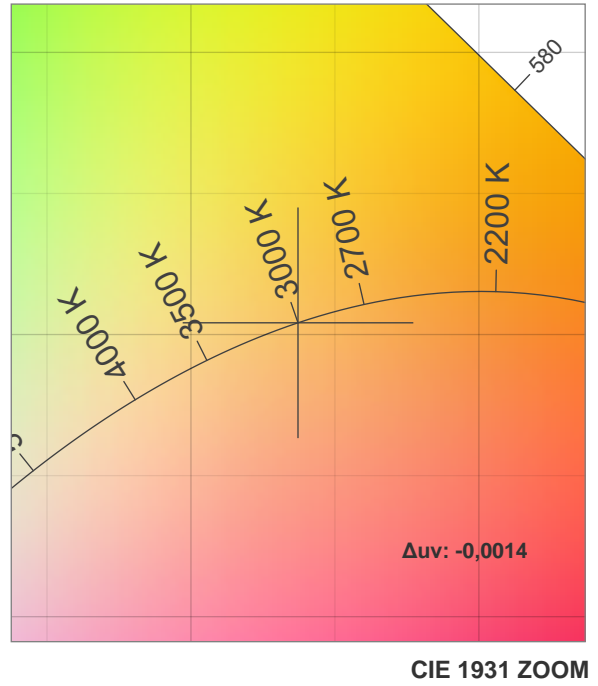
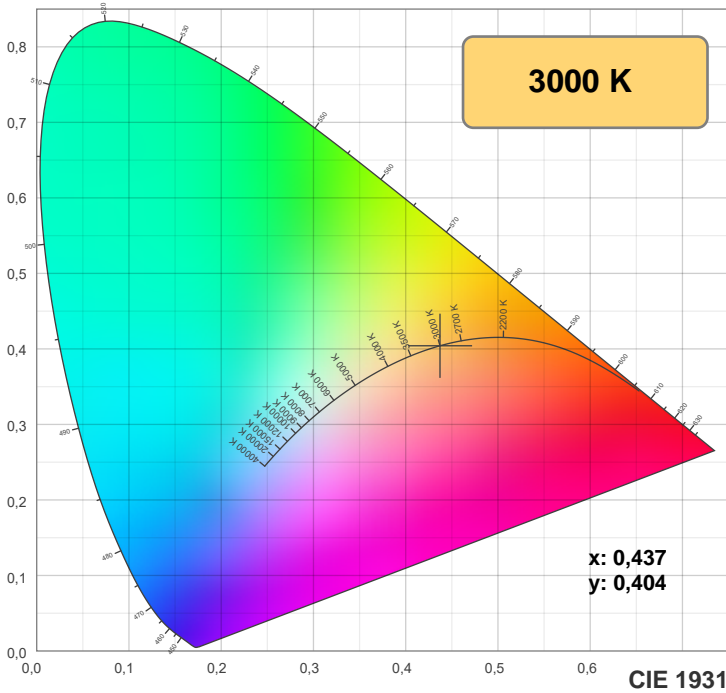

TM-30: 85,5

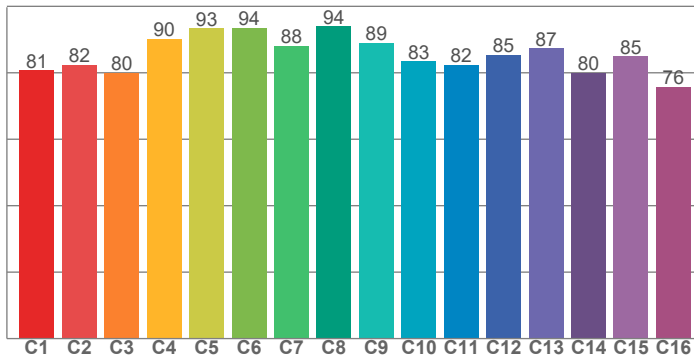

CRI: 84,1 (R1-R8)

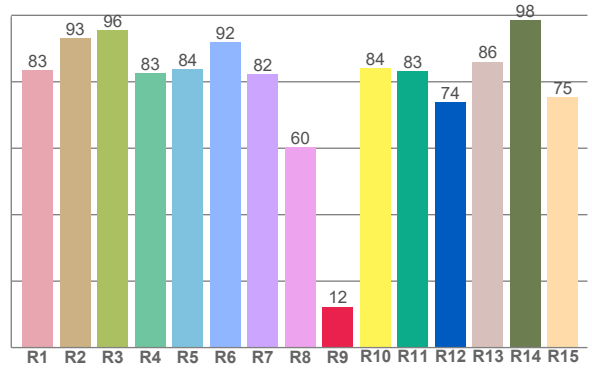

CQS: 83,0

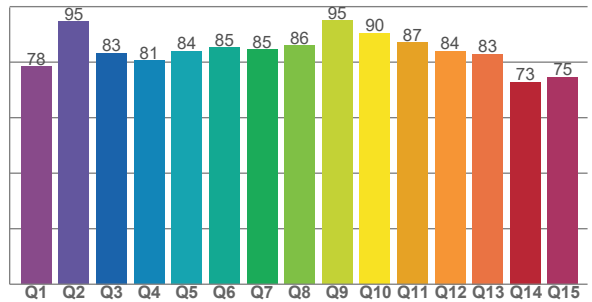

CRI R values, only R1-R8 are used to calculate final CRI value

R1	R2	R3	R4	R5	R6	R7	R8	R9	R10	R11	R12	R13	R14	R15
83,5	93,0	95,5	82,6	83,8	91,9	82,4	60,4	12,3	84,1	83,2	73,8	86,1	98,4	75,3

TM30 C values, 16 binned values out of total of 99 C values

C1	C2	C3	C4	C5	C6	C7	C8	C9	C10	C11	C12	C13	C14	C15	C16
80,8	82,5	80,0	90,2	93,3	93,5	88,1	94,0	89,0	83,4	82,4	85,4	87,4	79,9	85,0	75,8

CQS Q values

Q1	Q2	Q3	Q4	Q5	Q6	Q7	Q8	Q9	Q10	Q11	Q12	Q13	Q14	Q15
78,5	94,6	83,4	80,6	84,1	85,3	84,6	86,0	95,1	90,4	87,1	84,1	83,0	72,8	74,6

Color parameters

Color temperature	Color rendering index	Red component	Color fidelity	Color gamut	Color quality scale	Color coordinate cie 1931	Color coordinate cie 1931	Color coordinate	Color coordinate	Color deviation from black body
CCT	CRI	CRI R9	TM30 Rf	TM30 Rg	CQS	x	y	u	v	Δuv
3000 K	84,1	12,3	85,5	96,2	83,0	0,437	0,404	0,251	0,348	-0,0014

Rf 85,5
Fidelity index Rf

Rg 96,2
Gamut index Rg

Hue Bin	R _f	Shifts (%)	
		Chroma	Hue
1	81	-11%	0%
2	82	-7%	7%
3	80	-3%	10%
4	90	-1%	5%
5	93	2%	3%
6	94	2%	-2%
7	88	-4%	-5%
8	94	-3%	-1%
9	89	-5%	4%
10	83	-3%	10%
11	82	1%	13%
12	85	7%	2%
13	87	5%	-8%
14	80	5%	-16%
15	85	-3%	-9%
16	76	-8%	-17%

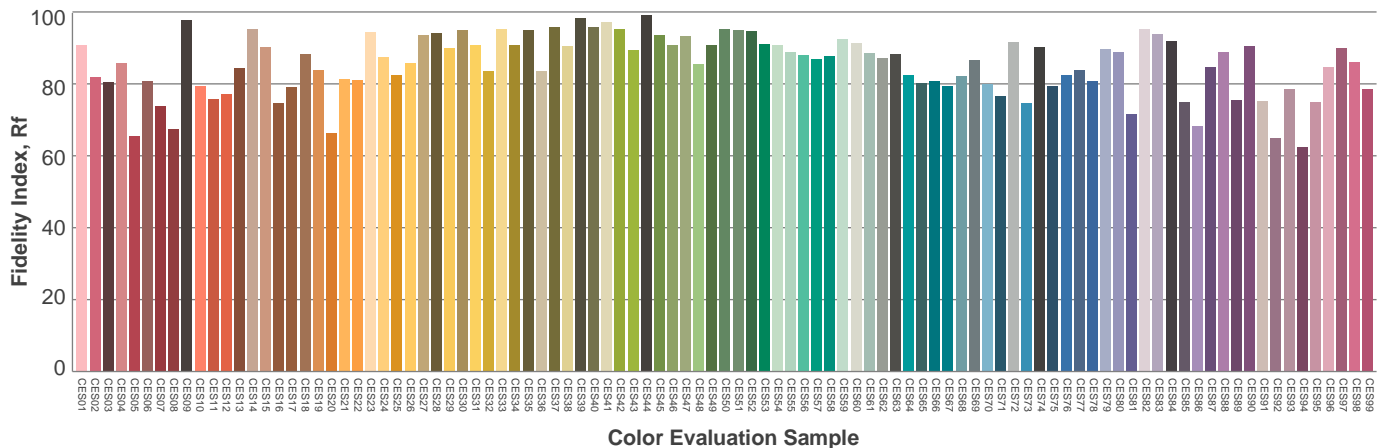
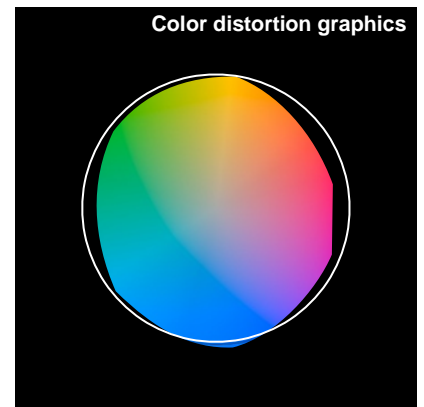
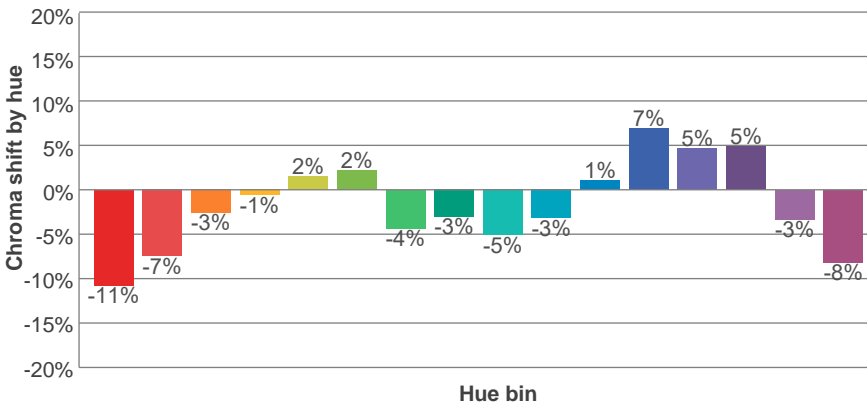
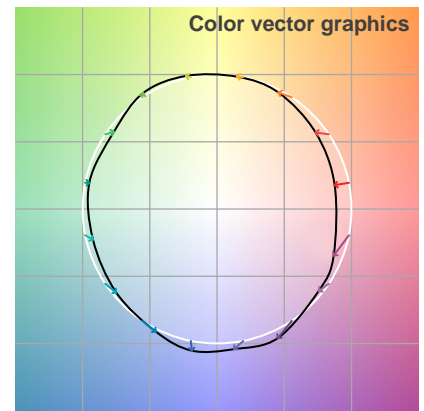
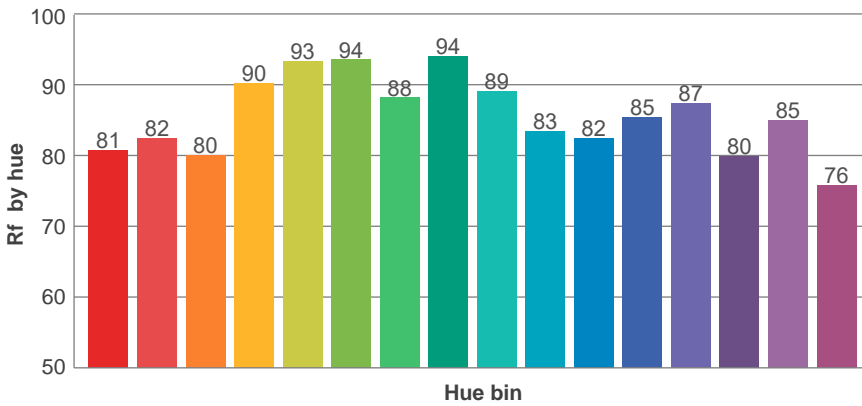
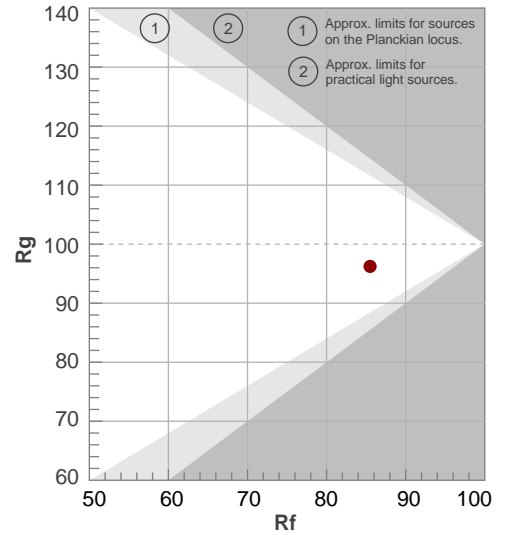

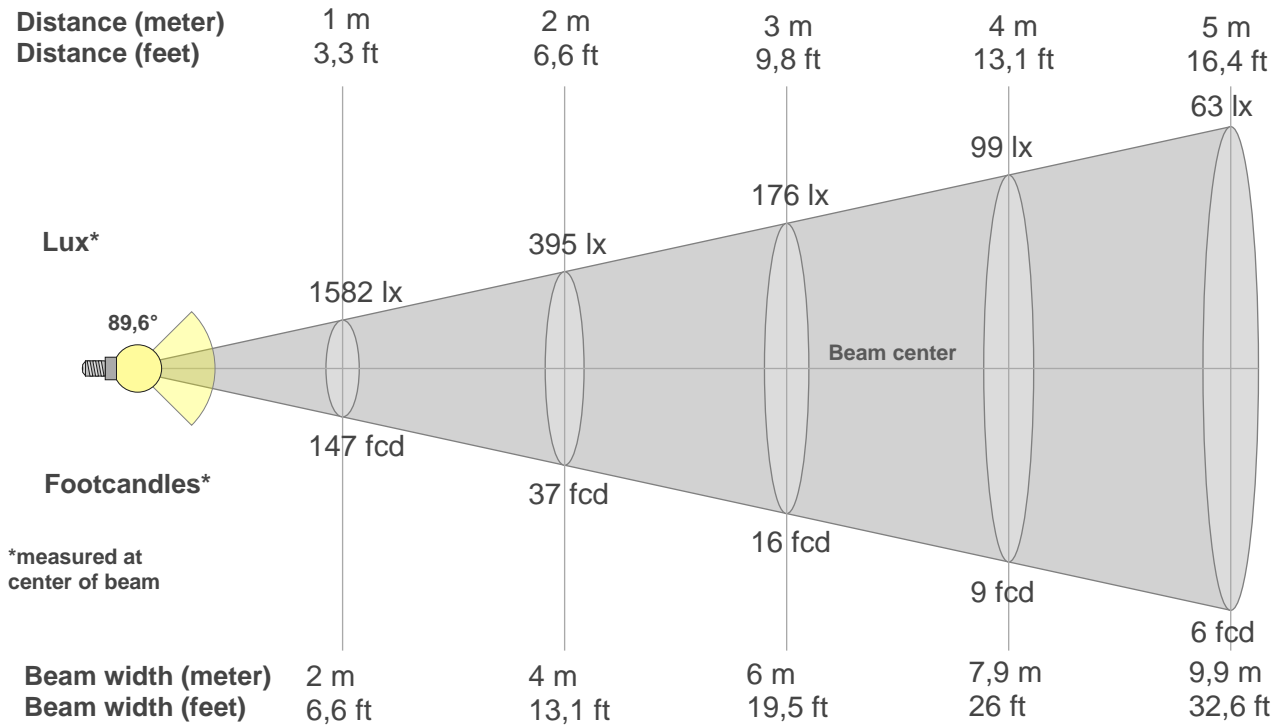

Beam intensities from 1-20m

1m	2m	3m	4m	5m	6m	7m	8m	9m	10m	11m	12m	13m	14m	15m	16m	17m	18m	19m	20m
3,3ft	6,6ft	9,8ft	13,1ft	16,4ft	19,7ft	23ft	26,2ft	29,5ft	32,8ft	36,1ft	39,4ft	42,7ft	45,9ft	49,2ft	52,5ft	55,8ft	59,1ft	62,3ft	65,6ft
1582lx	395lx	176lx	99lx	63lx	44lx	32lx	25lx	20lx	16lx	13lx	11lx	9lx	8lx	7lx	6lx	5lx	5lx	4lx	4lx
146,9fcd	36,7fcd	16,3fcd	9,2fcd	5,9fcd	4,1fcd	3fcd	2,3fcd	1,8fcd	1,5fcd	1,2fcd	1fcd	0,9fcd	0,7fcd	0,7fcd	0,6fcd	0,5fcd	0,5fcd	0,4fcd	0,4fcd

Intensities in 0° c-plane

0°	5°	10°	15°	20°	25°	30°	35°	40°	45°	50°	55°	60°	65°	70°	75°	80°	85°	90°	95°
1582	1578	1564	1537	1496	1432	1340	1214	1021	781	595	454	327	235	181	142	90	47	14	5
100%	100%	99%	97%	95%	91%	85%	77%	65%	49%	38%	29%	21%	15%	11%	9%	6%	3%	1%	0%

Intensities in 90° c-plane

0°	5°	10°	15°	20°	25°	30°	35°	40°	45°	50°	55°	60°	65°	70°	75°	80°	85°	90°	95°
1582	1578	1564	1537	1496	1432	1340	1214	1021	781	595	454	327	235	181	142	90	47	14	5
100%	100%	99%	97%	95%	91%	85%	77%	65%	49%	38%	29%	21%	15%	11%	9%	6%	3%	1%	0%

Intensities in 180° c-plane

0°	5°	10°	15°	20°	25°	30°	35°	40°	45°	50°	55°	60°	65°	70°	75°	80°	85°	90°	95°
1582	1578	1564	1537	1496	1432	1340	1214	1021	781	595	454	327	235	181	142	90	47	14	5
100%	100%	99%	97%	95%	91%	85%	77%	65%	49%	38%	29%	21%	15%	11%	9%	6%	3%	1%	0%

Intensities in 270° c-plane

0°	5°	10°	15°	20°	25°	30°	35°	40°	45°	50°	55°	60°	65°	70°	75°	80°	85°	90°	95°
1582	1578	1564	1537	1496	1432	1340	1214	1021	781	595	454	327	235	181	142	90	47	14	5
100%	100%	99%	97%	95%	91%	85%	77%	65%	49%	38%	29%	21%	15%	11%	9%	6%	3%	1%	0%

Beam angle 50%	Field angle 10%	Cutoff angle 2,5%	Intensity ratio in 120° cone	Intensity ratio in 90° cone
89,6°	145,7°	172°	86,3%	66,8%

iso-candela diagram

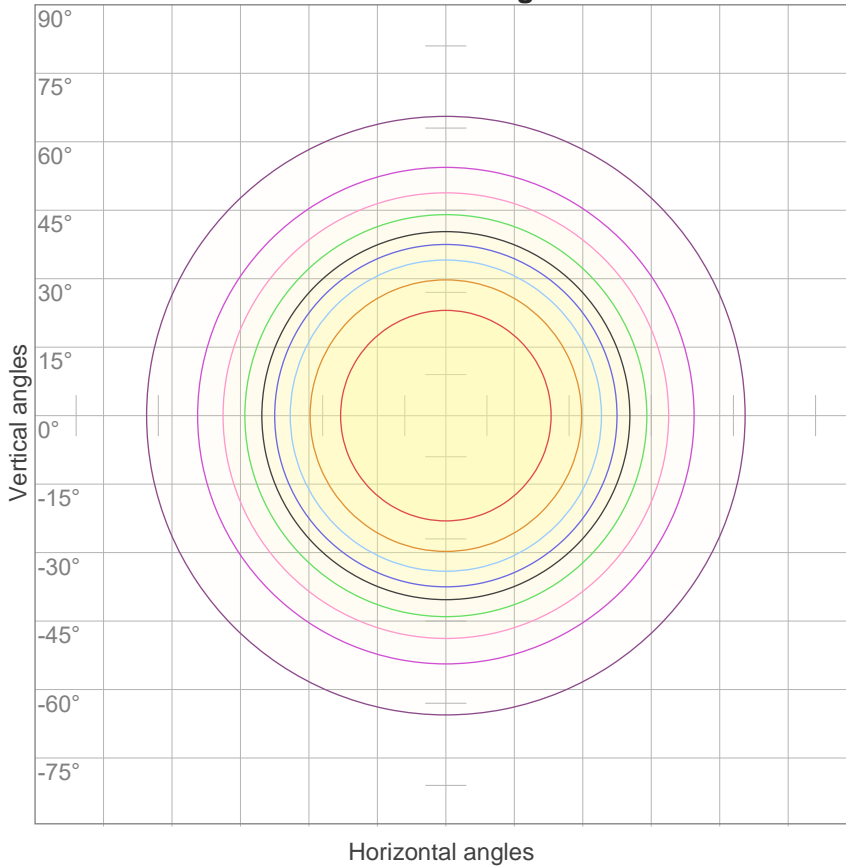

10%	158 cd
20%	316 cd
30%	474 cd
40%	633 cd
50%	791 cd
60%	949 cd
70%	1107 cd
80%	1265 cd
90%	1423 cd

Conditions:

Number of c-planes: 16

Candela at center: 1582 cd

iso-lux diagram

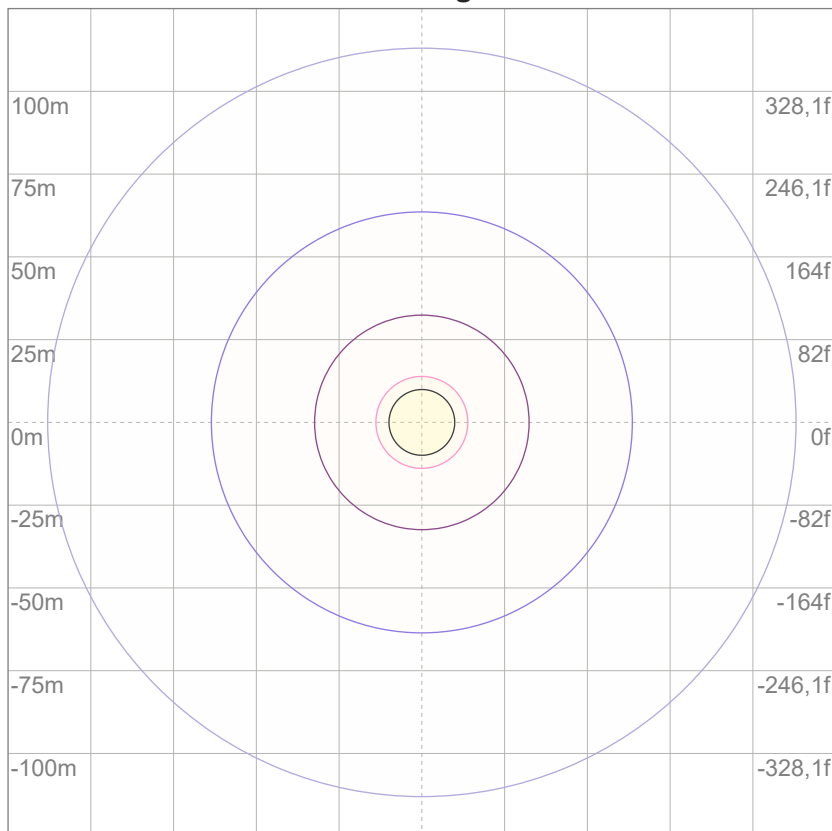

3%	0,474 lx
5%	0,791 lx
10%	1,58 lx
30%	4,74 lx
50%	7,91 lx

Conditions:

Number of c-planes: 16

Lux at center: 15,8 lx

Lux distribution on a surface when lamp is mounted at 10 meters from the surface.

Glare evaluation according to UGR

p Ceiling		70	70	50	50	30	70	70	50	50	30
p Walls		50	30	50	30	30	50	30	50	30	30
p Floor		20	20	20	20	20	20	20	20	20	20
Room size X Y		Viewing direction at right angles to lamp axis					Viewing direction parallel to lamp axis				
2H	2H	15,3	16,3	15,5	16,6	16,8	15,2	16,2	15,4	16,5	16,8
	3H	16,0	17,1	16,4	17,4	17,6	15,9	17,0	16,3	17,3	17,5
	4H	16,4	17,5	16,8	17,8	18,0	16,3	17,4	16,7	17,6	17,9
	6H	16,9	17,8	17,2	18,1	18,5	16,7	17,6	17,0	17,9	18,3
	8H	17,0	17,9	17,4	18,2	18,7	16,8	17,7	17,2	18,1	18,5
	12H	17,1	18,0	17,5	18,3	18,8	16,9	17,8	17,3	18,1	18,6
4H	2H	15,5	16,5	15,9	16,8	17,1	15,4	16,5	15,8	16,8	17,0
	3H	16,6	17,4	16,9	17,8	18,3	16,5	17,3	16,9	17,7	18,2
	4H	17,1	17,9	17,6	18,3	18,9	17,0	17,8	17,4	18,2	18,8
	6H	17,6	18,4	18,1	18,8	19,2	17,5	18,2	18,0	18,6	19,0
	8H	17,8	18,5	18,4	18,9	19,3	17,7	18,4	18,2	18,7	19,1
	12H	18,0	18,6	18,5	19,0	19,5	17,8	18,4	18,3	18,8	19,3
8H	4H	17,3	18,0	17,8	18,4	18,8	17,2	17,9	17,7	18,3	18,7
	6H	18,0	18,5	18,5	19,0	19,6	17,9	18,4	18,4	18,9	19,4
	8H	18,3	18,8	18,9	19,3	20,0	18,2	18,6	18,7	19,1	19,8
	12H	18,6	19,0	19,2	19,5	20,1	18,4	18,7	19,0	19,3	19,9
12H	4H	17,3	17,9	17,8	18,3	18,8	17,2	17,8	17,7	18,2	18,7
	6H	18,1	18,5	18,6	19,1	19,7	17,9	18,4	18,5	18,9	19,6
	8H	18,4	18,8	19,0	19,3	19,9	18,2	18,6	18,8	19,1	19,8
Variation of the observer position for the luminaire distance S											
S = 1.0H		0,2 / -0,3					0,2 / -0,3				
S = 1.5H		0,5 / -0,6					0,6 / -0,6				
S = 2.0H		1,2 / -1,0					1,2 / -1,0				
CIE 117-1995. Corrected glare indices referring to 3482 lm total luminous flux											

Coefficients of Utilization

Ceiling reflectance	80				70				50			30			10			0			
Wall reflectance	70	50	30	10	70	50	30	10	50	30	10	50	30	10	50	30	10	0			
Floor reflectance	20	20	20	20	20	20	20	20	20	20	20	20	20	20	20	20	20	20	20	20	0
RCR	(RCR: Room Cavity Ratio)																				
	Room Values are expressed as percentage of Lumens delivered to the task surface																				
0	119	119	119	119	116	116	116	116	111	111	111	106	106	106	101	101	101	99			
1	110	106	102	99	107	103	100	97	99	96	94	95	93	91	91	89	88	86			
2	101	94	88	83	99	92	87	82	88	84	80	85	81	78	82	79	76	74			
3	93	84	77	71	91	82	76	70	79	74	69	77	72	68	74	70	66	64			
4	86	76	68	62	84	74	67	61	72	65	60	69	64	59	67	62	59	56			
5	80	68	60	54	78	67	60	54	65	58	53	63	57	53	61	56	52	50			
6	74	62	54	48	73	61	53	48	59	53	47	58	52	47	56	51	46	45			
7	69	57	49	43	68	56	48	43	54	48	43	53	47	42	52	46	42	40			
8	65	52	44	39	63	51	44	39	50	43	38	49	43	38	48	42	38	36			
9	61	48	40	35	59	48	40	35	46	40	35	45	39	35	44	39	35	33			
10	57	45	37	32	56	44	37	32	43	37	32	42	36	32	41	36	32	30			

LAMPS (number of lamps)

Luminaire budgetary diagram

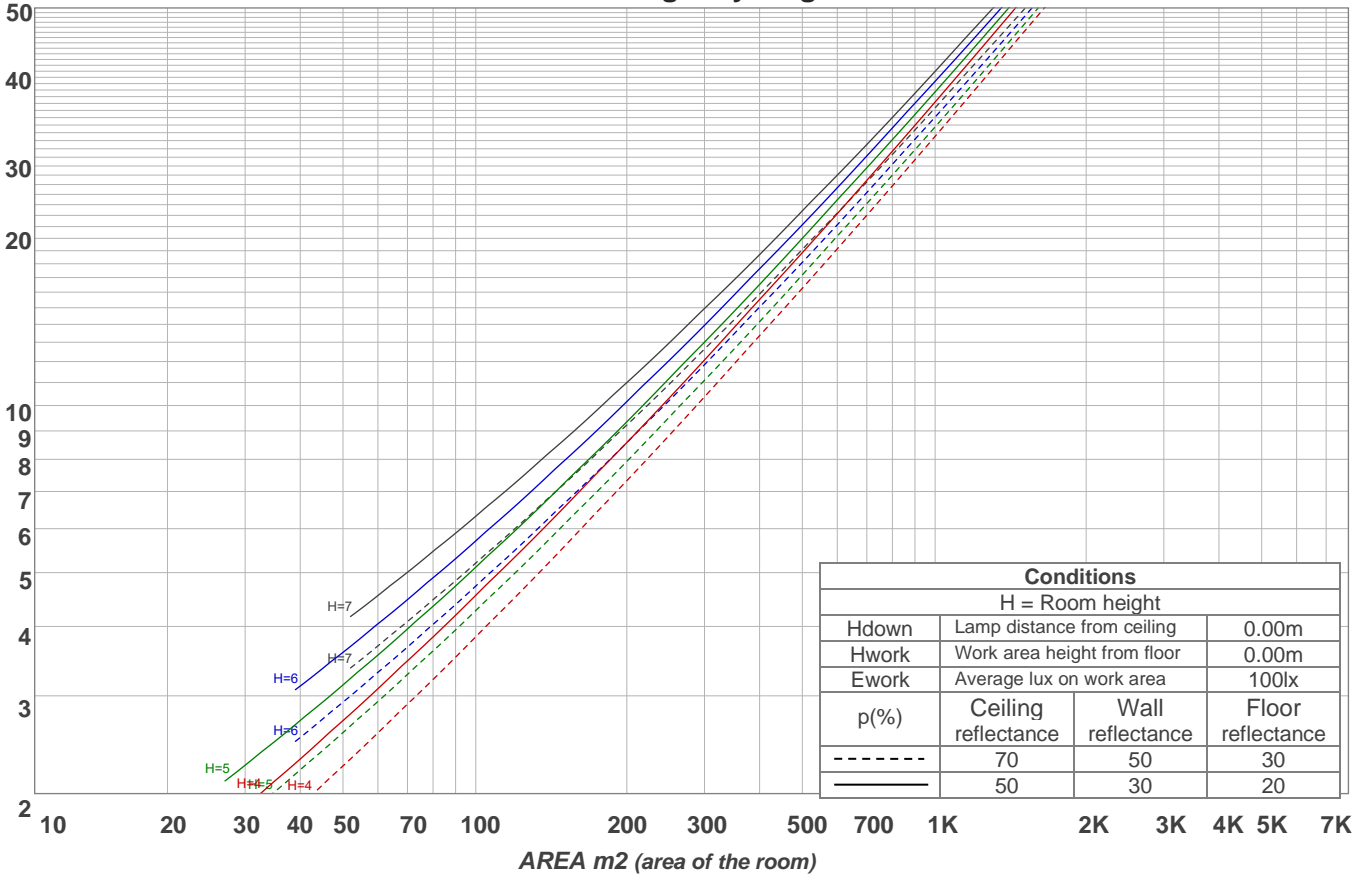

Zonal Lumen Summary

0°-10°	10°-20°	20°-30°	30°-40°	40°-50°	50°-60°	60°-70°	70°-80°	80°-90°
{LUM0-10}	434 lm	658 lm	750 lm	609 lm	406 lm	239 lm	146 lm	53,0 lm
90°-100°	100°-110°	110°-120°	120°-130°	130°-140°	140°-150°	150°-160°	160°-170°	170°-180°
6,87 lm	4,95 lm	4,97 lm	5,01 lm	5,02 lm	4,17 lm	3,31 lm	2,06 lm	0,699 lm

LCS table

BUG rating:	B2 U2 G1	
Forward light	Lumens	Lumens %
Low(0-30):	620,6	17,8%
Medium(30-60):	882,5	25,3%
High(60-80):	192,9	5,5%
Very high(80-90):	26,6	0,8%
Back light		
Low(0-30):	620,6	17,8%
Medium(30-60):	882,5	25,3%
High(60-80):	192,9	5,5%
Very high(80-90):	26,6	0,8%
Uplight		
Low(90-100):	7,1	0,2%
High(100-180):	30,2	0,9%

LCS graph

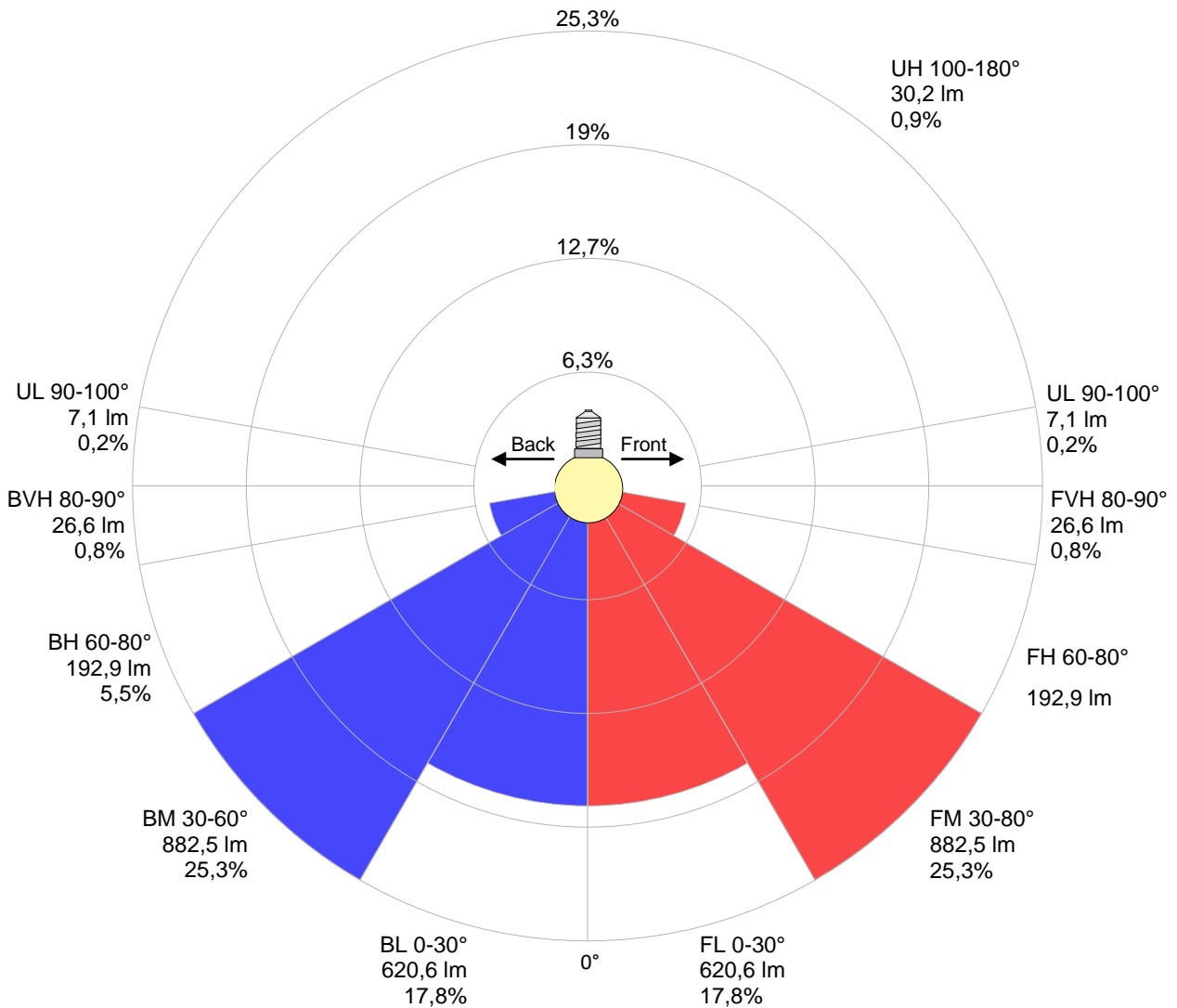

Warmup curve

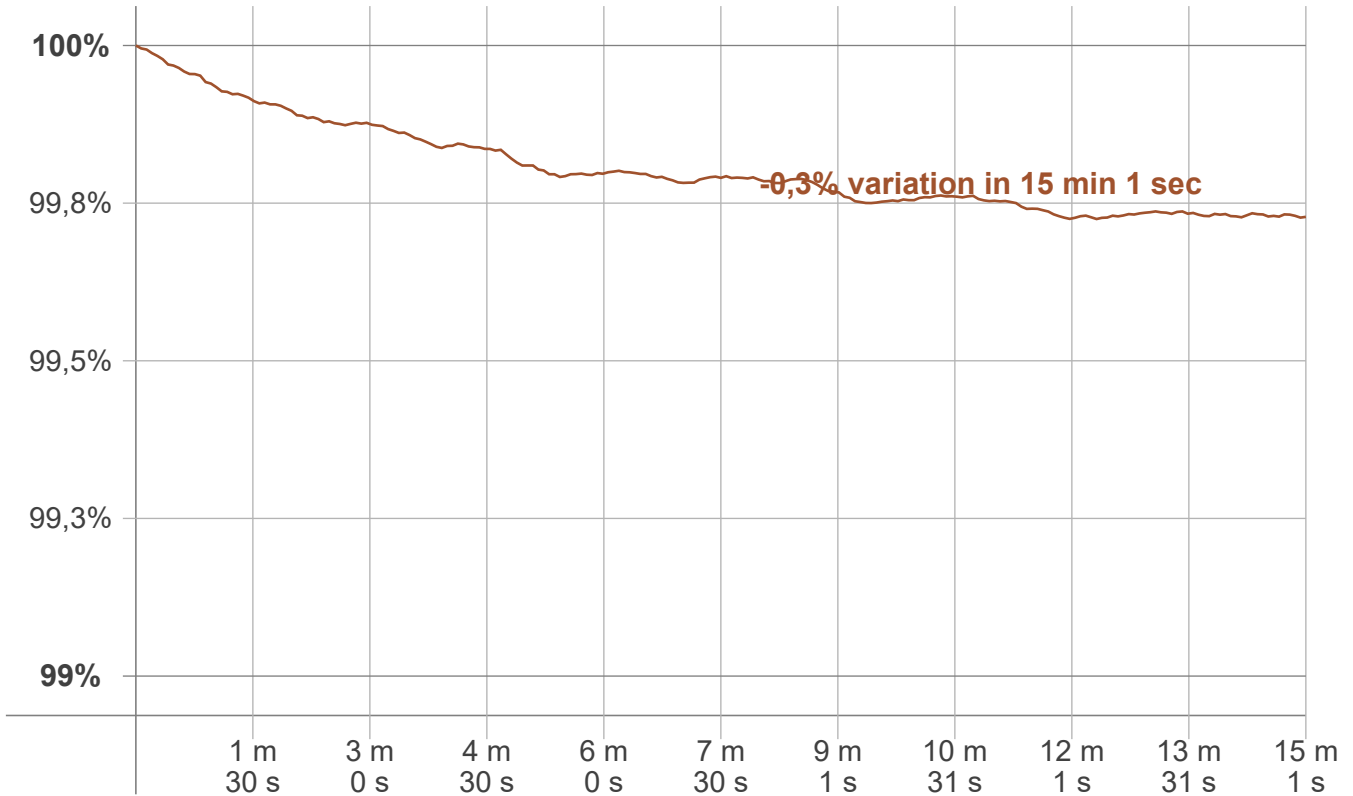

Warmup result

Warmup time:	Lamp stabilized in 15 min 1 sec
Warmup variation	-0,3%

Warmup conditions

Stable period:	15 min
Stable change max:	2,0%
Minimum time:	15 min

Color temperature change

CCT start	CCT change	CCT end
2997 K	+3 K	3000 K

Output change

Output start	Output change	Output end
3492 lm	-10 lm	3482 lm

Flicker curve (complete sampled flicker signal)



Flicker frame (frame of one flicker period)

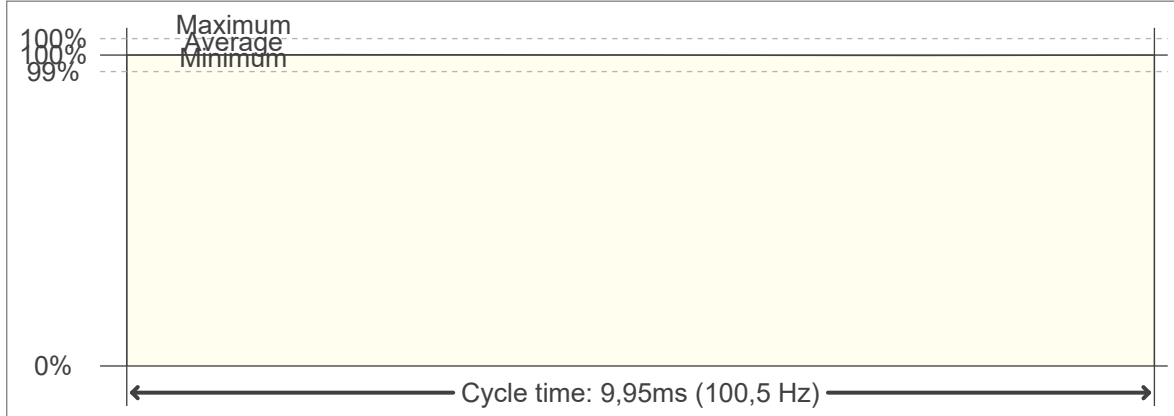

Flicker FFT (frequency scope of flicker curve)



Flicker results:

Flicker frequency:		100,5 Hz	
Flicker index:	0	JA8/10 40Hz	0,01 %
Flicker percentage:	0,17 %	JA8/10 90Hz	0,02 %
SVM: (Visual flicker)	0,01	JA8/10 200Hz	0,17 %
PstLM	0,01	JA8/10 400Hz	0,17 %
Mp	0,01	JA8/10 1000Hz	0,17 %

Flicker conditions:

Sample rate:	20000 samples/second
--------------	----------------------