

Light efficiency:



Light quality:



Color temperature:



Output: 3632 lm

Peak: 1740 cd

Power: 24,5 W

PF: 0,96



Tracking number: [VT241001-007291](#)

Product name:

802257-6000K

Item number:

802257-6000K

Date and time:

1-10-2024 10:47:05

Description:

**BACK-LIT LED PANEEL | CUPID |
120X30CM | 25W**

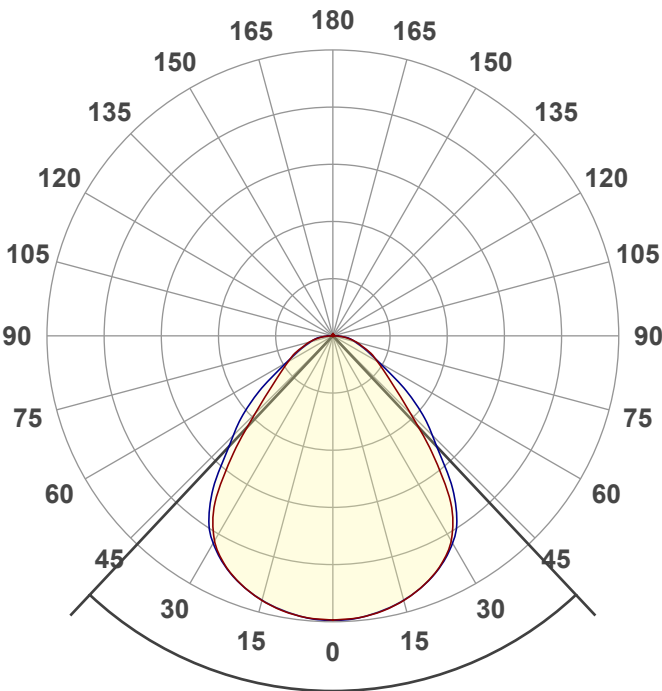

Beam angle **86,4°**



CIE 1931
x: 0,322
y: 0,332

Spectra

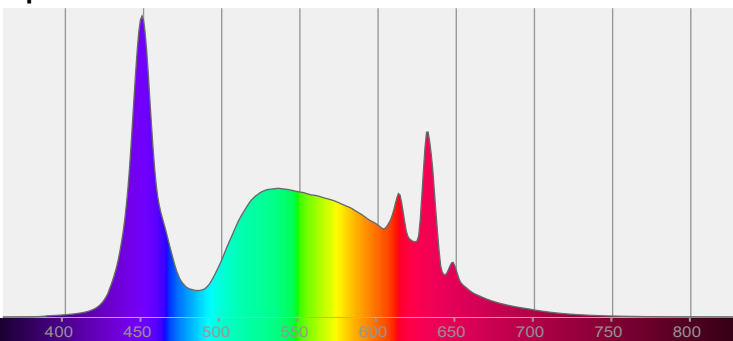

Power

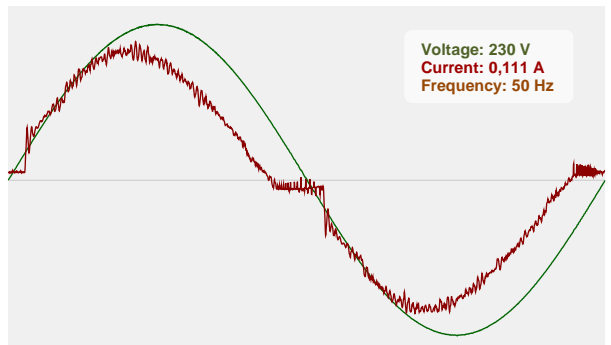

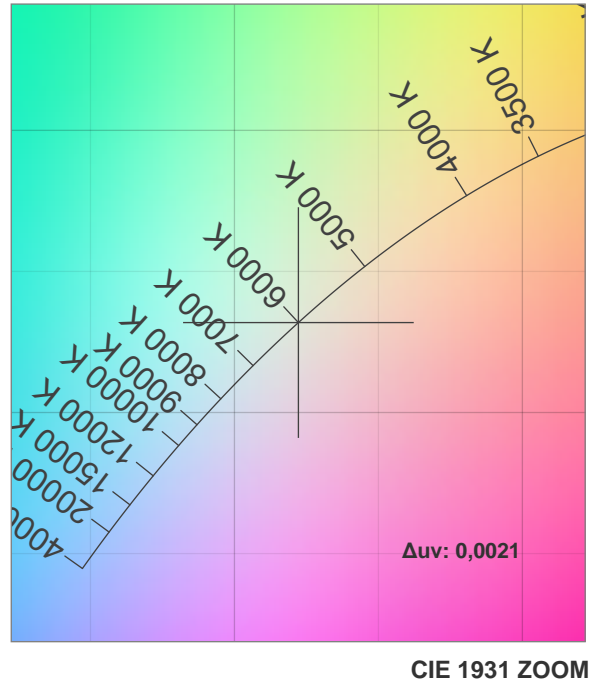
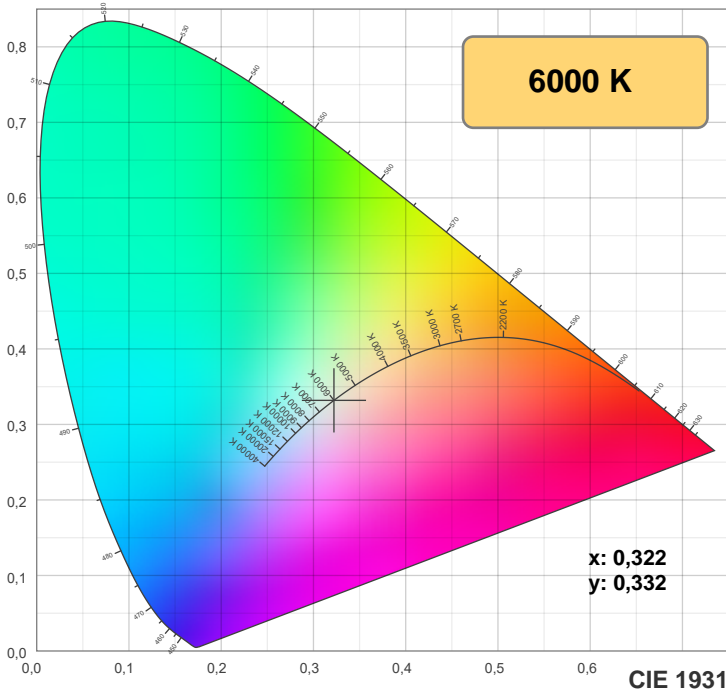

TM-30: 80,3

CRI: 82,1 (R1-R8)

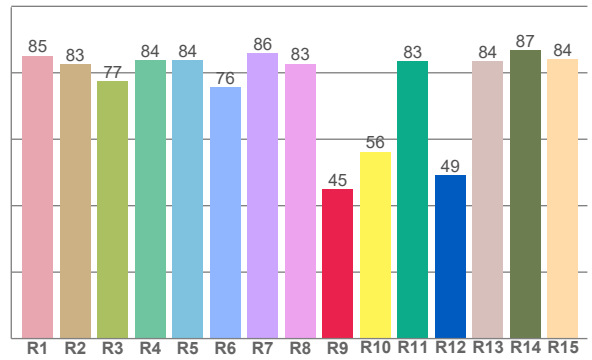
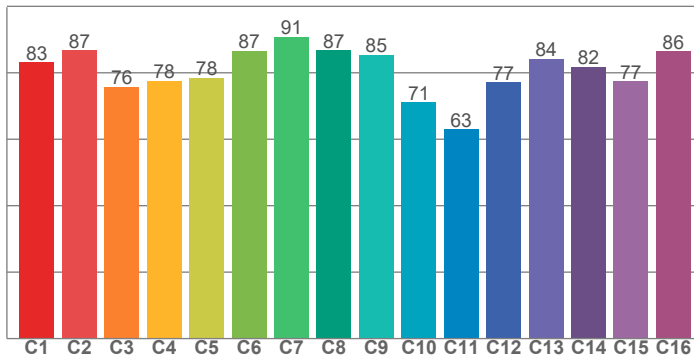

CQS: 80,3

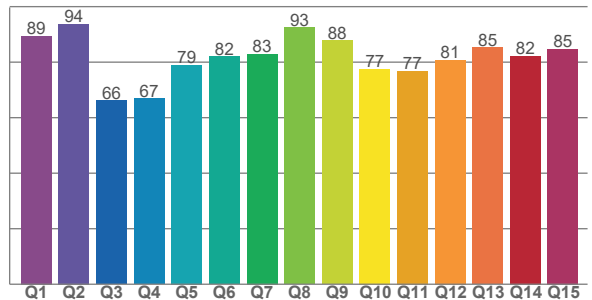

CRI R values, only R1-R8 are used to calculate final CRI value

R1	R2	R3	R4	R5	R6	R7	R8	R9	R10	R11	R12	R13	R14	R15
85,1	82,6	77,5	83,8	83,7	75,6	86,0	82,8	45,0	56,2	83,4	49,2	83,6	86,9	84,1

TM30 C values, 16 binned values out of total of 99 C values

C1	C2	C3	C4	C5	C6	C7	C8	C9	C10	C11	C12	C13	C14	C15	C16
83,2	86,7	75,8	77,6	78,5	86,7	90,8	86,8	85,4	71,1	63,0	77,1	84,2	81,8	77,4	86,5

CQS Q values

Q1	Q2	Q3	Q4	Q5	Q6	Q7	Q8	Q9	Q10	Q11	Q12	Q13	Q14	Q15
89,5	93,8	66,3	66,9	79,0	82,1	82,9	92,5	87,8	77,5	76,8	80,8	85,2	82,2	84,8

Color parameters

Color temperature	Color rendering index	Red component	Color fidelity	Color gamut	Color quality scale	Color coordinate cie 1931	Color coordinate cie 1931	Color coordinate	Color coordinate	Color deviation from black body
CCT	CRI	CRI R9	TM30 Rf	TM30 Rg	CQS	x	y	u	v	Δuv
6000 K	82,1	45,0	80,3	101,1	80,3	0,322	0,332	0,203	0,314	0,0021

Rf 80,3
Fidelity index Rf

Rg 101,1
Gamut index Rg

Hue Bin	R _f	Shifts (%)	
		Chroma	Hue
1	83	-8%	-3%
2	87	-7%	4%
3	76	-3%	14%
4	78	3%	14%
5	78	7%	10%
6	87	9%	1%
7	91	3%	-5%
8	87	-5%	-5%
9	85	-12%	4%
10	71	-9%	15%
11	63	-1%	23%
12	77	5%	15%
13	84	12%	6%
14	82	10%	-1%
15	77	13%	-16%
16	86	0%	-8%

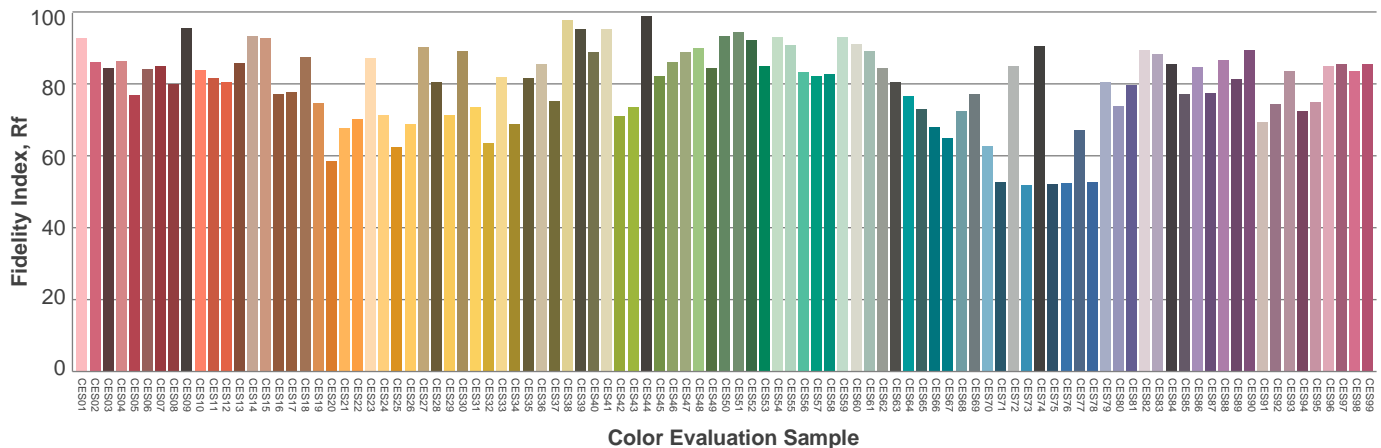
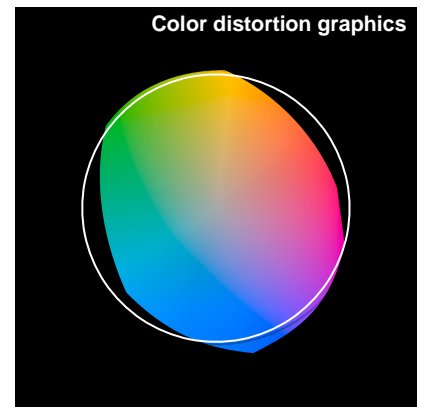
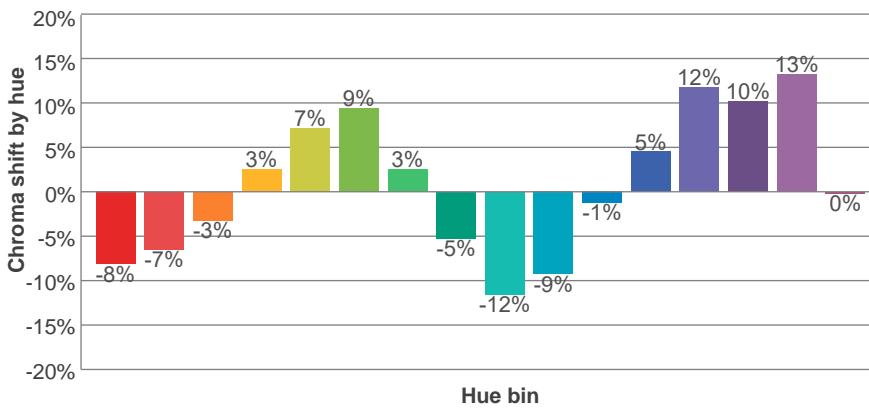
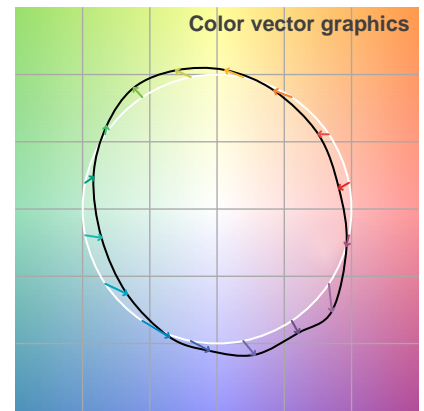
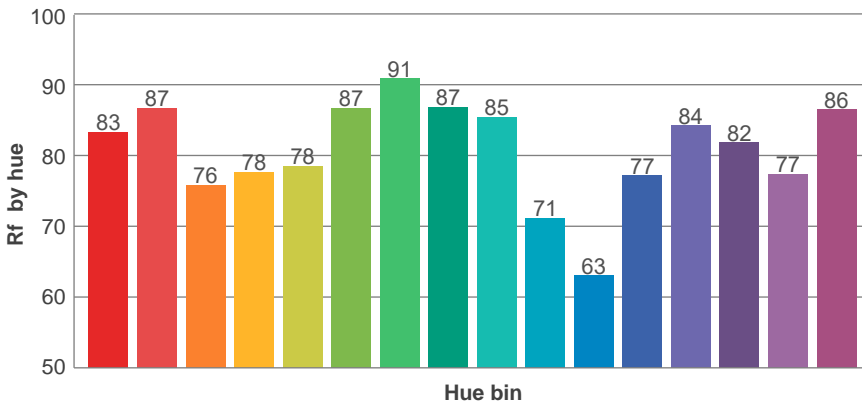
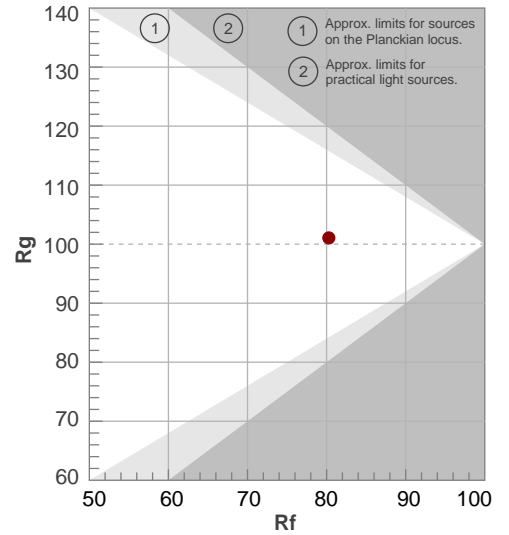

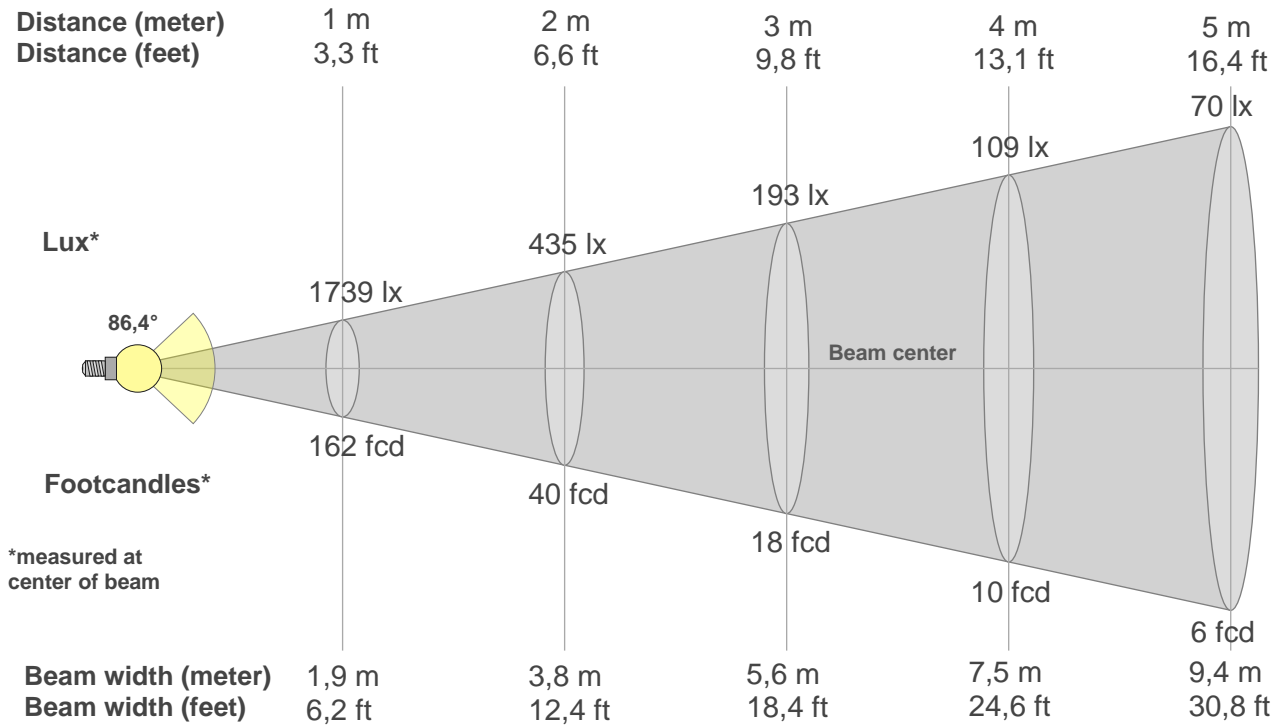

Beam intensities from 1-20m

1m	2m	3m	4m	5m	6m	7m	8m	9m	10m	11m	12m	13m	14m	15m	16m	17m	18m	19m	20m
3,3ft	6,6ft	9,8ft	13,1ft	16,4ft	19,7ft	23ft	26,2ft	29,5ft	32,8ft	36,1ft	39,4ft	42,7ft	45,9ft	49,2ft	52,5ft	55,8ft	59,1ft	62,3ft	65,6ft
1739lx	435lx	193lx	109lx	70lx	48lx	35lx	27lx	21lx	17lx	14lx	12lx	10lx	9lx	8lx	7lx	6lx	5lx	5lx	4lx
161,6fcd	40,4fcd	18fcd	10,1fcd	6,5fcd	4,5fcd	3,3fcd	2,5fcd	2fcd	1,6fcd	1,3fcd	1,1fcd	1fcd	0,8fcd	0,7fcd	0,6fcd	0,6fcd	0,5fcd	0,4fcd	0,4fcd

Intensities in 0° c-plane

0°	5°	10°	15°	20°	25°	30°	35°	40°	45°	50°	55°	60°	65°	70°	75°	80°	85°	90°	95°
1739	1731	1710	1674	1622	1551	1445	1258	958	676	497	389	315	260	195	150	101	56	12	5
100%	100%	98%	96%	93%	89%	83%	72%	55%	39%	29%	22%	18%	15%	11%	9%	6%	3%	1%	0%

Intensities in 90° c-plane

0°	5°	10°	15°	20°	25°	30°	35°	40°	45°	50°	55°	60°	65°	70°	75°	80°	85°	90°	95°
1739	1730	1707	1671	1621	1553	1458	1310	1090	864	682	493	336	244	184	140	107	63	18	4
100%	99%	98%	96%	93%	89%	84%	75%	63%	50%	39%	28%	19%	14%	11%	8%	6%	4%	1%	0%

Intensities in 180° c-plane

0°	5°	10°	15°	20°	25°	30°	35°	40°	45°	50°	55°	60°	65°	70°	75°	80°	85°	90°	95°
1739	1731	1710	1674	1622	1551	1445	1258	958	676	497	389	315	260	195	150	101	56	12	5
100%	100%	98%	96%	93%	89%	83%	72%	55%	39%	29%	22%	18%	15%	11%	9%	6%	3%	1%	0%

Intensities in 270° c-plane

0°	5°	10°	15°	20°	25°	30°	35°	40°	45°	50°	55°	60°	65°	70°	75°	80°	85°	90°	95°
1739	1730	1707	1671	1621	1553	1458	1310	1090	864	682	493	336	244	184	140	107	63	18	4
100%	99%	98%	96%	93%	89%	84%	75%	63%	50%	39%	28%	19%	14%	11%	8%	6%	4%	1%	0%

Beam angle 50%	Field angle 10%	Cutoff angle 2,5%	Intensity ratio in 120° cone	Intensity ratio in 90° cone
86,4°	143,1°	172,4°	86,2%	68,2%

iso-candela diagram

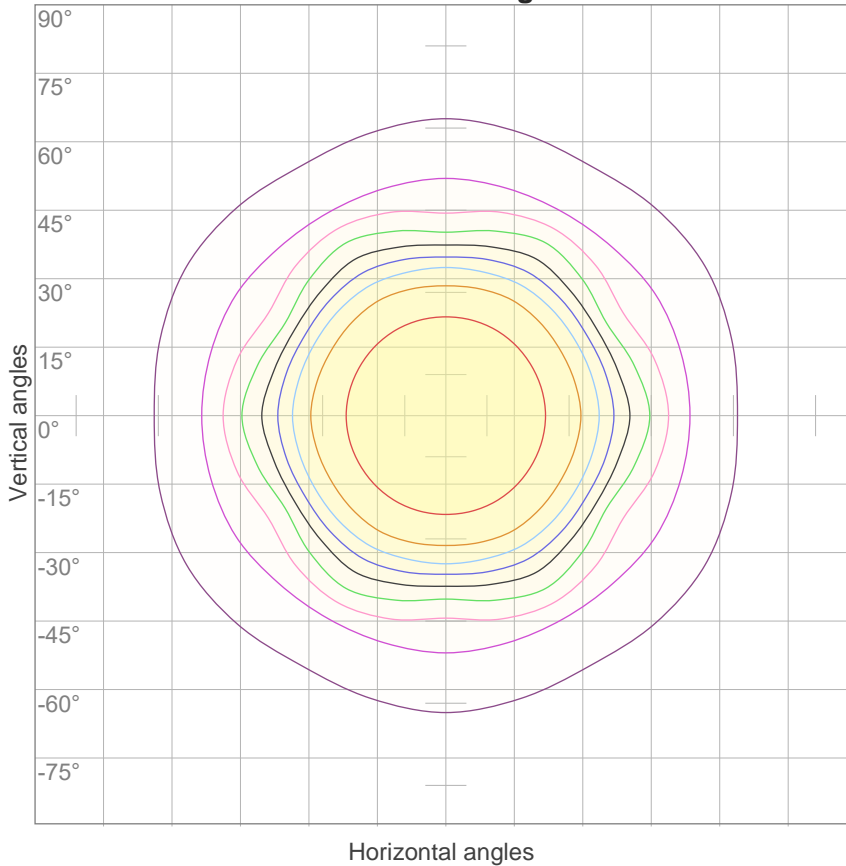

10%	174 cd
20%	348 cd
30%	522 cd
40%	696 cd
50%	869 cd
60%	1043 cd
70%	1217 cd
80%	1391 cd
90%	1565 cd

Conditions:

Number of c-planes: 12

Candela at center: 1739 cd

iso-lux diagram

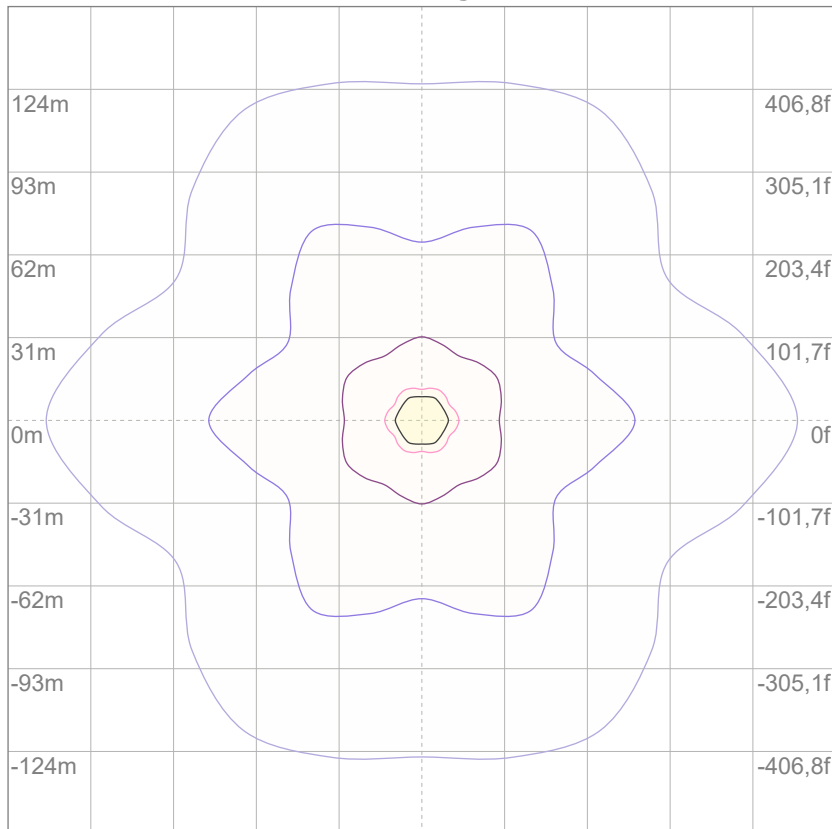

3%	0,522 lx
5%	0,869 lx
10%	1,74 lx
30%	5,22 lx
50%	8,69 lx

Conditions:

Number of c-planes: 12

Lux at center: 17,4 lx

Lux distribution on a surface when lamp is mounted at 10 meters from the surface.

Glare evaluation according to UGR

p Ceiling	70	70	50	50	30	70	70	50	50	30	
p Walls	50	30	50	30	30	50	30	50	30	30	
p Floor	20	20	20	20	20	20	20	20	20	20	
Room size X Y	Viewing direction at right angles to lamp axis					Viewing direction parallel to lamp axis					
2H	2H	14,9	16,0	15,1	16,3	16,5	15,2	16,3	15,4	16,6	16,8
	3H	15,8	16,9	16,2	17,2	17,4	16,0	17,1	16,4	17,4	17,6
	4H	16,3	17,4	16,7	17,6	17,9	16,4	17,5	16,9	17,8	18,0
	6H	16,9	17,8	17,2	18,1	18,5	16,9	17,8	17,2	18,1	18,5
	8H	17,1	18,0	17,4	18,3	18,7	17,1	18,0	17,4	18,3	18,7
	12H	17,2	18,1	17,6	18,4	18,9	17,2	18,1	17,6	18,4	18,9
4H	2H	15,2	16,2	15,6	16,5	16,8	15,5	16,5	15,9	16,8	17,1
	3H	16,4	17,3	16,8	17,6	18,1	16,7	17,5	17,1	17,9	18,4
	4H	17,0	17,8	17,5	18,2	18,8	17,2	18,0	17,6	18,4	18,9
	6H	17,7	18,5	18,2	18,8	19,2	17,7	18,5	18,2	18,8	19,2
	8H	18,0	18,7	18,5	19,0	19,4	17,9	18,6	18,5	19,0	19,4
	12H	18,2	18,8	18,7	19,2	19,7	18,1	18,7	18,7	19,2	19,6
8H	4H	17,3	18,0	17,8	18,3	18,7	17,4	18,1	17,9	18,5	18,9
	6H	18,1	18,7	18,7	19,1	19,7	18,1	18,6	18,6	19,1	19,6
	8H	18,6	19,0	19,1	19,6	20,2	18,4	18,9	19,0	19,4	20,1
	12H	18,9	19,3	19,5	19,8	20,5	18,7	19,1	19,3	19,6	20,2
12H	4H	17,3	17,8	17,8	18,3	18,8	17,4	18,0	17,9	18,4	18,9
	6H	18,2	18,7	18,8	19,2	19,9	18,2	18,6	18,7	19,2	19,8
	8H	18,7	19,1	19,3	19,6	20,2	18,5	18,9	19,1	19,4	20,1
Variation of the observer position for the luminaire distance S											
S = 1.0H	0,2 / -0,3					0,2 / -0,2					
S = 1.5H	0,5 / -0,5					0,6 / -0,6					
S = 2.0H	1,0 / -0,8					1,2 / -0,9					
CIE 117-1995. Corrected glare indices referring to 3632 lm total luminous flux											

Coefficients of Utilization

Ceiling reflectance	80				70				50			30			10			0			
Wall reflectance	70	50	30	10	70	50	30	10	50	30	10	50	30	10	50	30	10	0			
Floor reflectance	20	20	20	20	20	20	20	20	20	20	20	20	20	20	20	20	20	20	20	20	0
RCR	(RCR: Room Cavity Ratio)																				
	Room Values are expressed as percentage of Lumens delivered to the task surface																				
0	119	119	119	119	116	116	116	116	111	111	111	106	106	106	101	101	101	99			
1	110	106	102	99	107	103	100	97	99	96	94	95	93	91	91	90	88	86			
2	101	94	88	83	99	92	87	82	89	84	80	85	82	78	82	79	76	74			
3	94	84	77	71	91	83	76	71	80	74	69	77	72	68	74	70	67	65			
4	87	76	68	62	85	75	67	62	72	66	61	70	64	60	68	63	59	57			
5	81	69	61	55	78	68	60	55	66	59	54	64	58	53	62	57	53	51			
6	75	63	55	49	73	62	54	49	60	53	48	58	52	48	57	51	47	45			
7	70	58	50	44	68	57	49	44	55	48	43	54	48	43	52	47	43	41			
8	65	53	45	40	64	52	45	40	51	44	39	50	43	39	48	43	39	37			
9	61	49	41	36	60	48	41	36	47	40	36	46	40	36	45	39	35	34			
10	58	45	38	33	56	45	38	33	44	37	33	43	37	33	42	36	32	31			

LAMPS (number of lamps)

Luminaire budgetary diagram

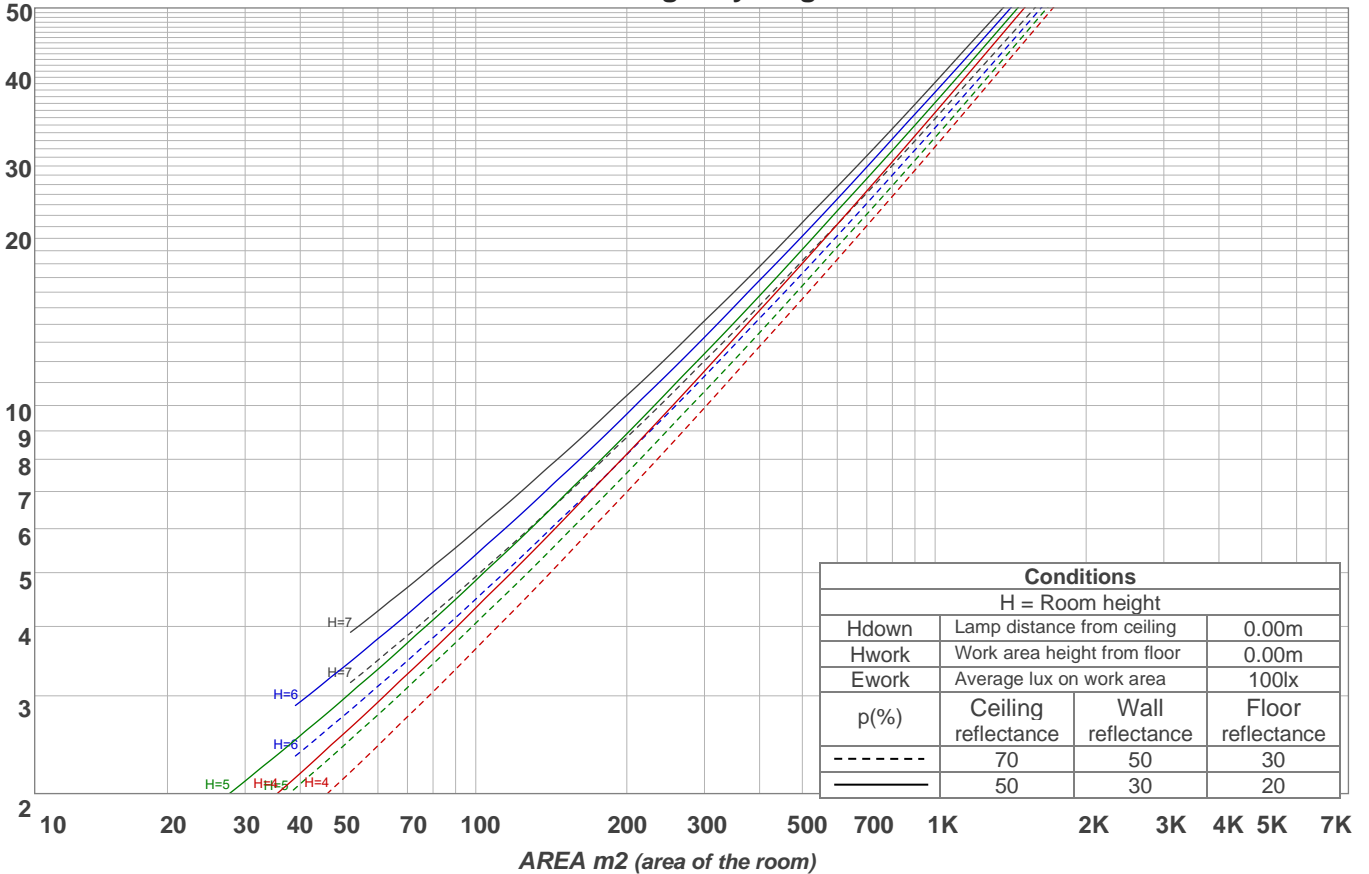

Zonal Lumen Summary

0°-10°	10°-20°	20°-30°	30°-40°	40°-50°	50°-60°	60°-70°	70°-80°	80°-90°
{LUM0-10}	472 lm	714 lm	795 lm	603 lm	383 lm	248 lm	153 lm	61,6 lm
90°-100°	100°-110°	110°-120°	120°-130°	130°-140°	140°-150°	150°-160°	160°-170°	170°-180°
5,63 lm	5,31 lm	5,55 lm	5,48 lm	5,05 lm	4,37 lm	3,57 lm	2,26 lm	0,770 lm

LCS table

BUG rating:	B2 U2 G1	
Forward light	Lumens	Lumens %
Low(0-30):	674,4	18,6%
Medium(30-60):	890,5	24,5%
High(60-80):	200,8	5,5%
Very high(80-90):	31	0,9%
Back light		
Low(0-30):	674,4	18,6%
Medium(30-60):	890,5	24,5%
High(60-80):	200,8	5,5%
Very high(80-90):	31	0,9%
Uplight		
Low(90-100):	6,4	0,2%
High(100-180):	32,3	0,9%

LCS graph

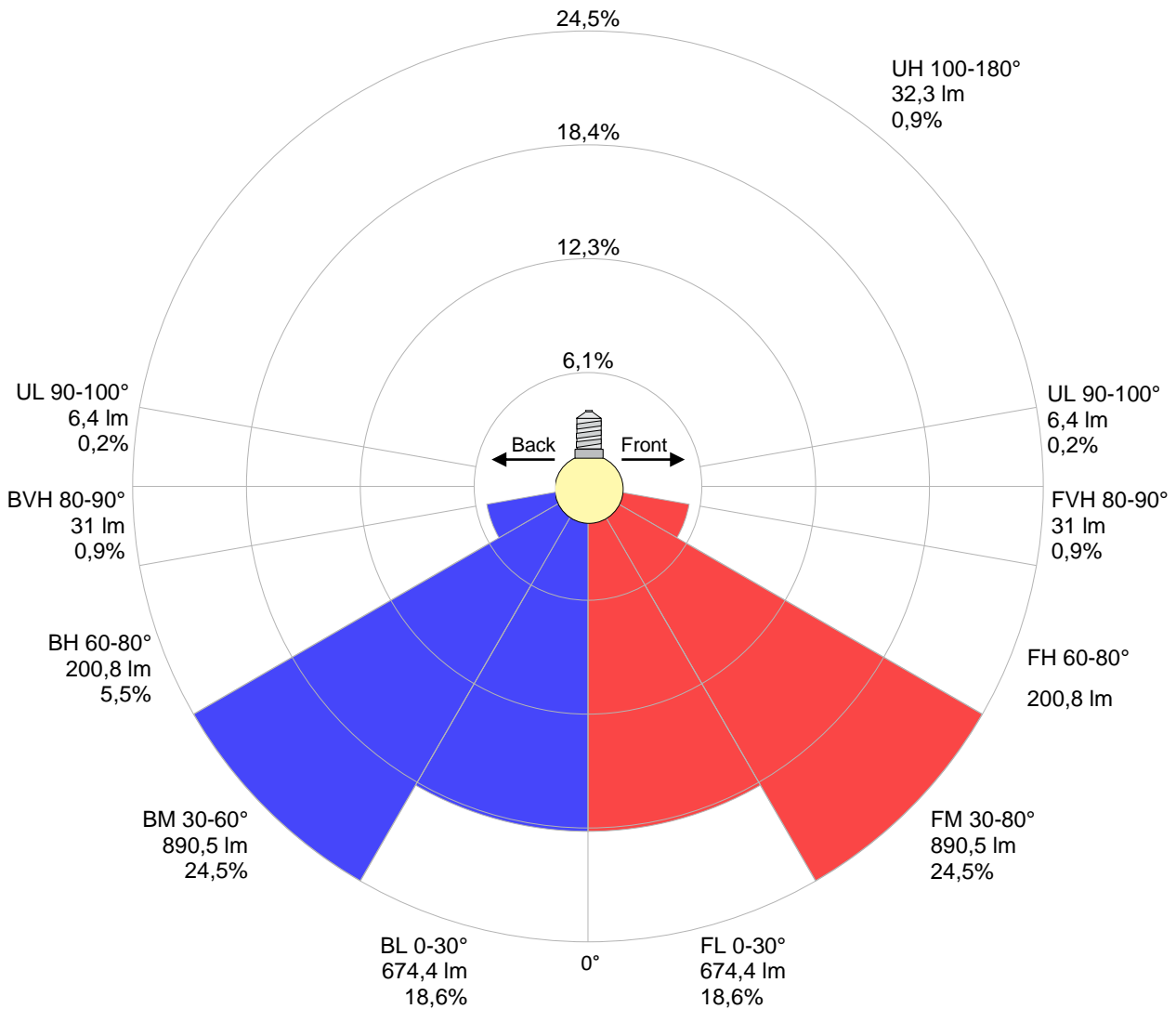

Warmup curve

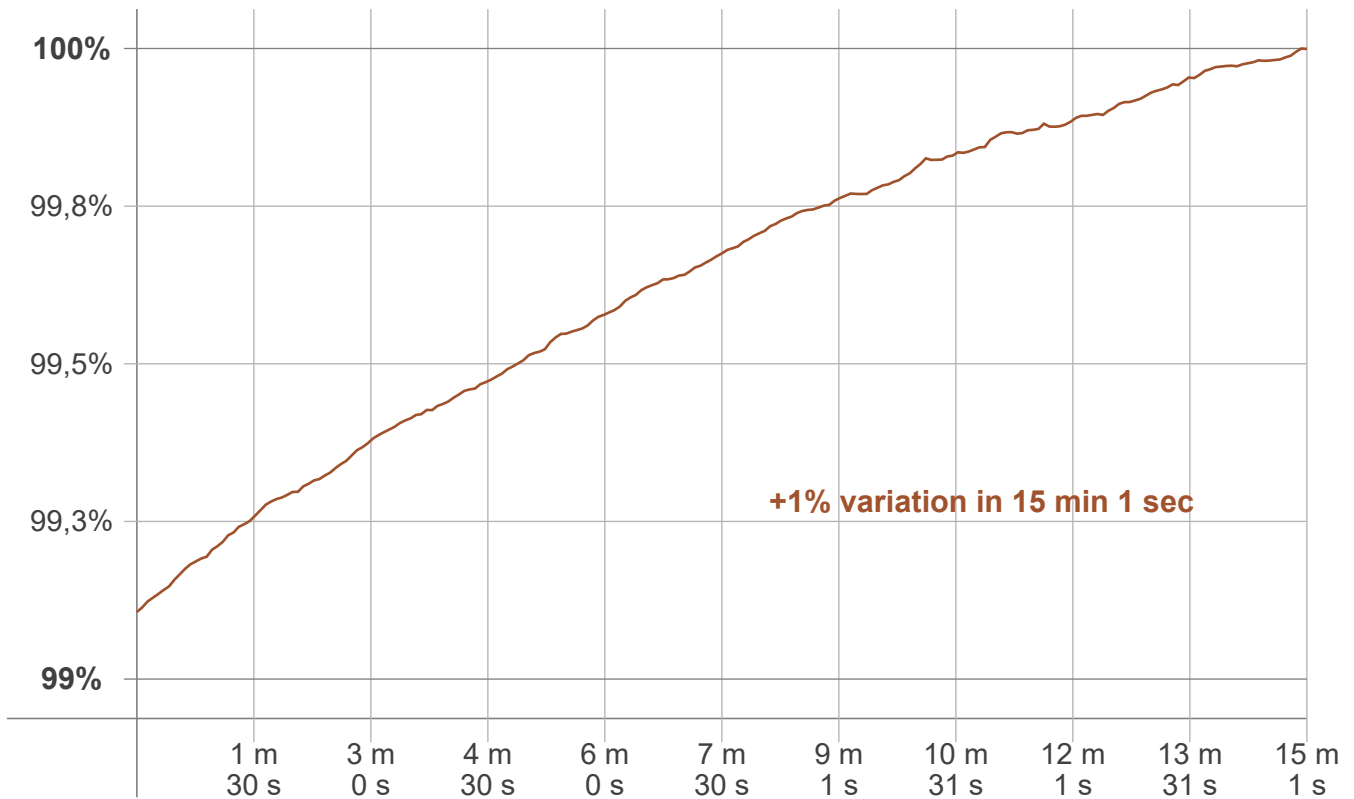

Warmup result

Warmup time:	Lamp stabilized in 15 min 1 sec
Warmup variation	+1,0%

Warmup conditions

Stable period:	15 min
Stable change max:	2,0%
Minimum time:	15 min

Color temperature change

CCT start	CCT change	CCT end
5979 K	+21 K	6000 K

Output change

Output start	Output change	Output end
3600 lm	+32 lm	3632 lm

Flicker curve (complete sampled flicker signal)



Flicker frame (frame of one flicker period)

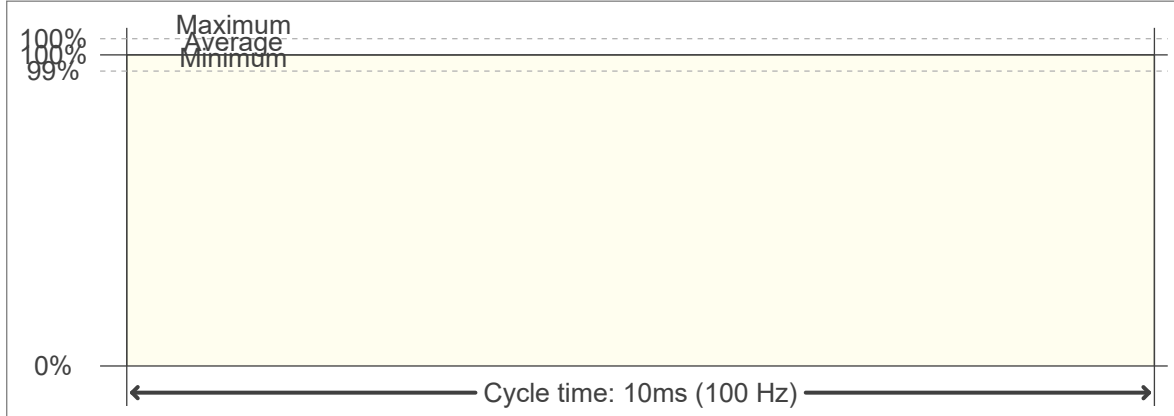

Flicker FFT (frequency scope of flicker curve)



Flicker results:

Flicker frequency:		100 Hz	
Flicker index:	0	JA8/10 40Hz	0,02 %
Flicker percentage:	0,11 %	JA8/10 90Hz	0,02 %
SVM: (Visual flicker)	0	JA8/10 200Hz	0,09 %
PstLM	0,01	JA8/10 400Hz	0,1 %
Mp	0,01	JA8/10 1000Hz	0,11 %

Flicker conditions:

Sample rate:	20000 samples/second
--------------	----------------------