

Light efficiency:



Light quality:



Color temperature:



Output: 4022 lm

Peak: 1353 cd

Power: 37,1 W

PF: 0,99



Tracking number: [VT240917-001452](#)

Product name:

803155

Item number:

803155

Date and time:

17-9-2024 10:01:26

Description:

**BACK-LIT LED PANEEL | ATHENE |
60X60CM | 36W | IP65 | 4000K**

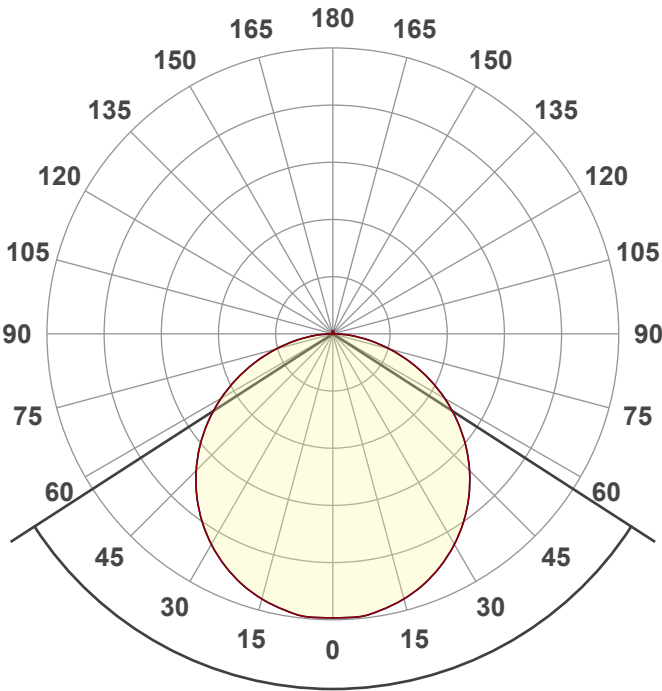

Beam angle **114,3°**



CIE 1931
x: 0,381
y: 0,377

Spectra

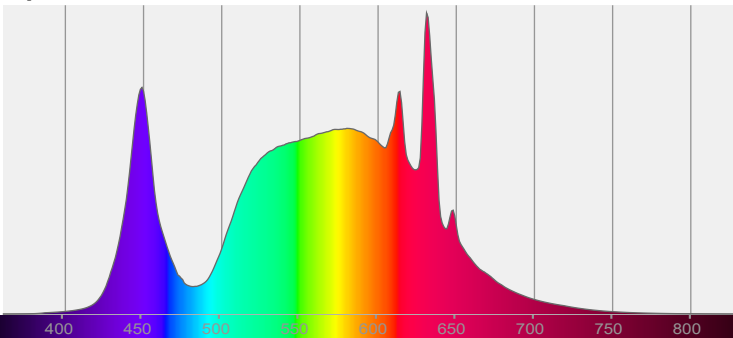

Power

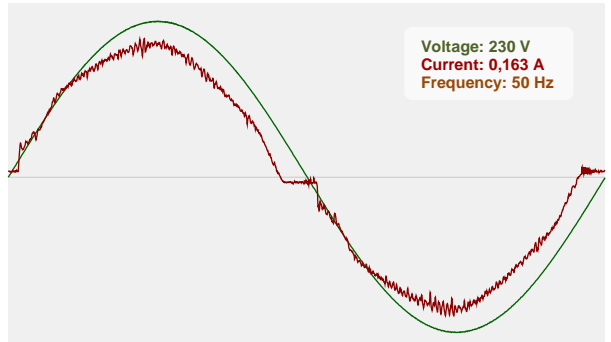

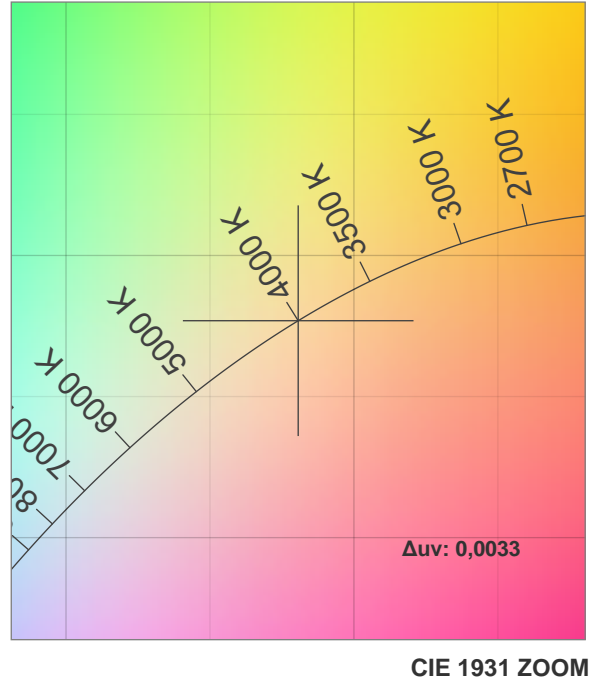
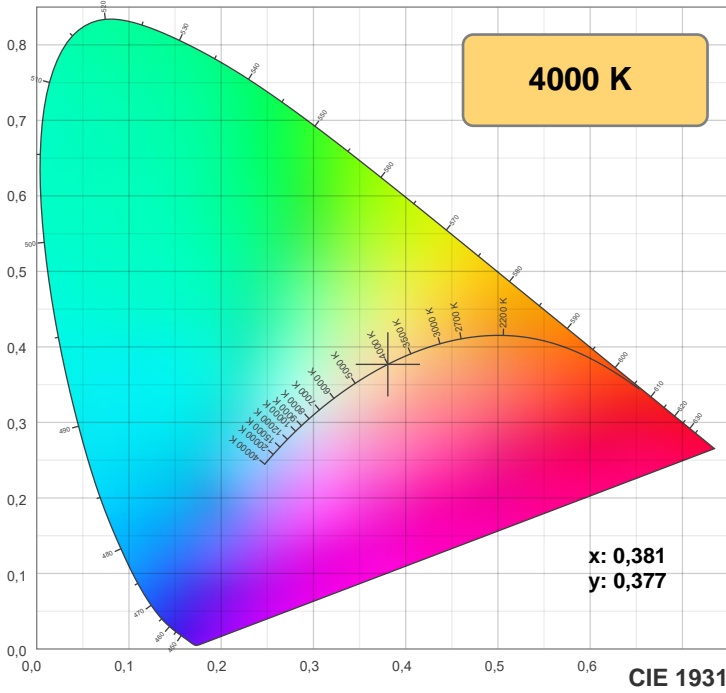

TM-30: 80,9

CRI: 80,4 (R1-R8)

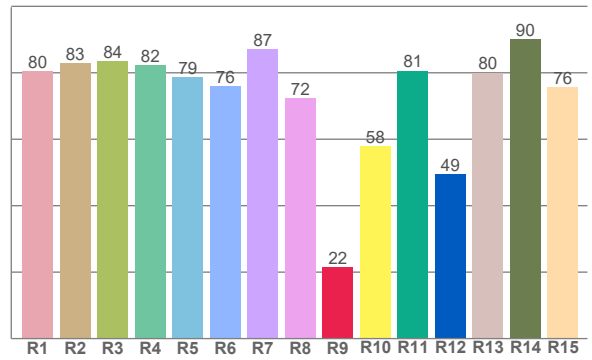
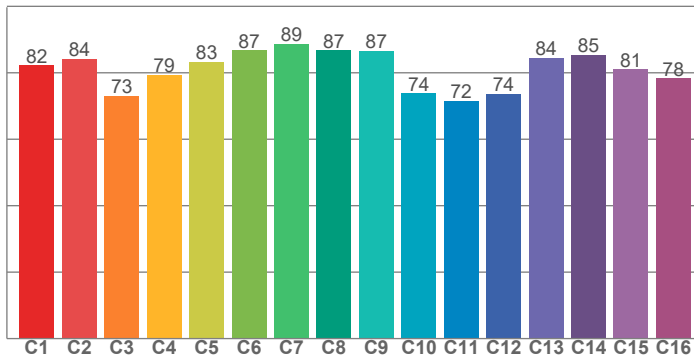

CQS: 80,9

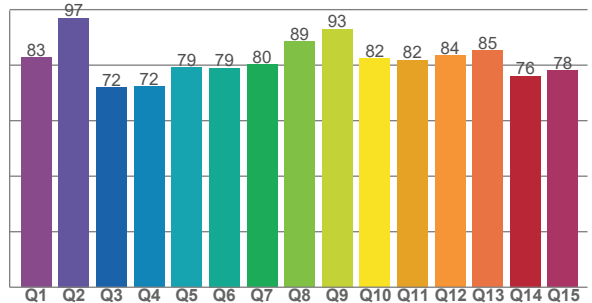

CRI R values, only R1-R8 are used to calculate final CRI value

R1	R2	R3	R4	R5	R6	R7	R8	R9	R10	R11	R12	R13	R14	R15
80,5	82,8	83,6	82,4	78,7	76,1	87,2	72,3	21,5	58,0	80,6	49,4	80,0	90,1	75,8

TM30 C values, 16 binned values out of total of 99 C values

C1	C2	C3	C4	C5	C6	C7	C8	C9	C10	C11	C12	C13	C14	C15	C16
82,2	84,2	73,1	79,4	83,4	86,8	88,8	86,8	86,6	73,8	71,6	73,7	84,5	85,3	81,0	78,3

CQS Q values

Q1	Q2	Q3	Q4	Q5	Q6	Q7	Q8	Q9	Q10	Q11	Q12	Q13	Q14	Q15
82,8	97,0	71,9	72,3	79,1	79,0	80,3	88,6	93,0	82,4	81,9	83,6	85,3	76,1	78,1

Color parameters

Color temperature	Color rendering index	Red component	Color fidelity	Color gamut	Color quality scale	Color coordinate cie 1931	Color coordinate cie 1931	Color coordinate	Color coordinate	Color divition from black body
CCT	CRI	CRI R9	TM30 Rf	TM30 Rg	CQS	x	y	u	v	Δuv
4000 K	80,4	21,5	80,9	99,1	80,9	0,381	0,377	0,225	0,334	0,0033

Rf 80,9
Fidelity index Rf

Rg 99,1
Gamut index Rg

Hue Bin	R _f	Shifts (%)	
		Chroma	Hue
1	82	-10%	-3%
2	84	-8%	5%
3	73	-4%	14%
4	79	3%	13%
5	83	7%	8%
6	87	9%	-1%
7	89	1%	-7%
8	87	-5%	-7%
9	87	-9%	-1%
10	74	-11%	11%
11	72	-1%	19%
12	74	6%	14%
13	84	10%	0%
14	85	13%	-1%
15	81	4%	-13%
16	78	-2%	-14%

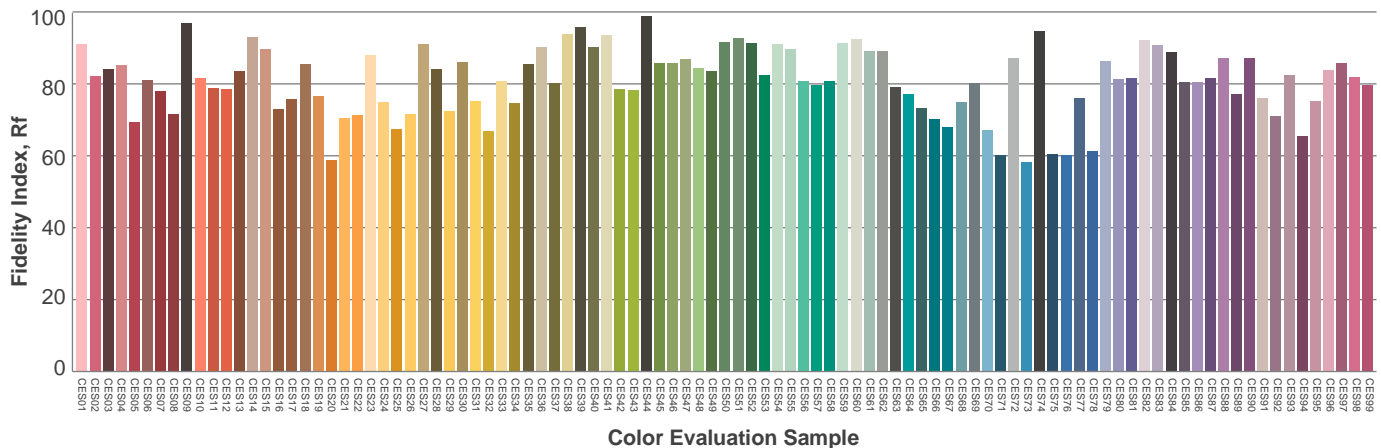
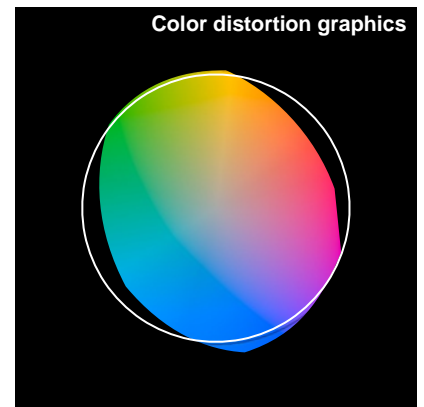
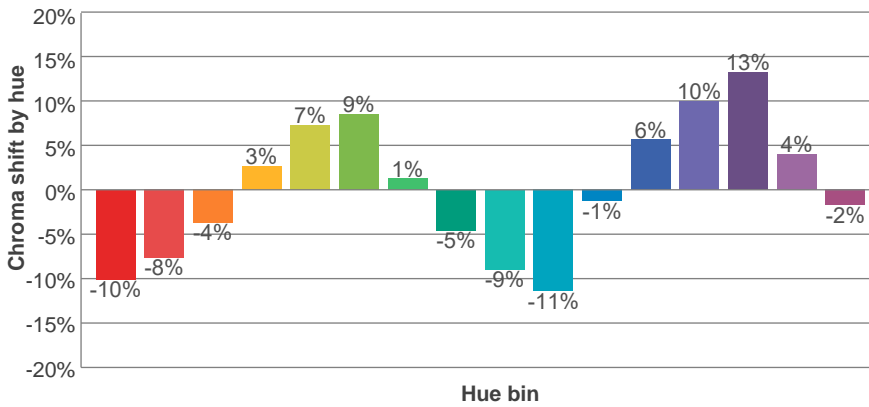
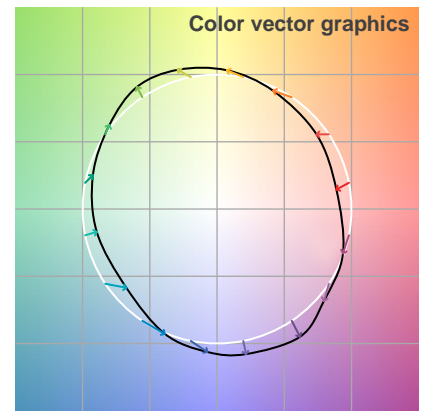
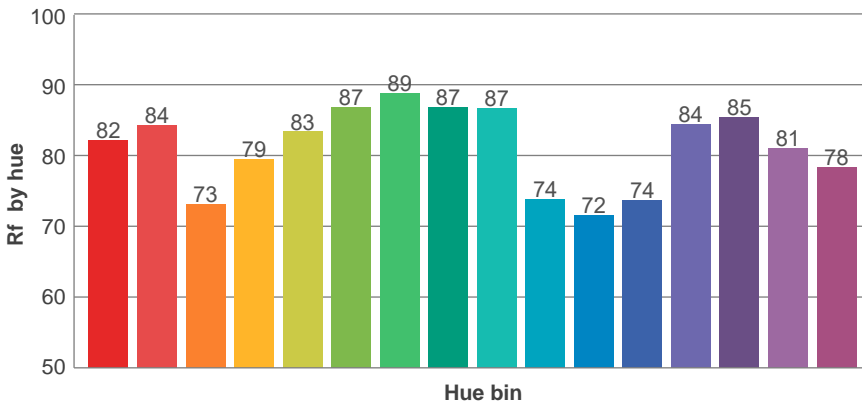
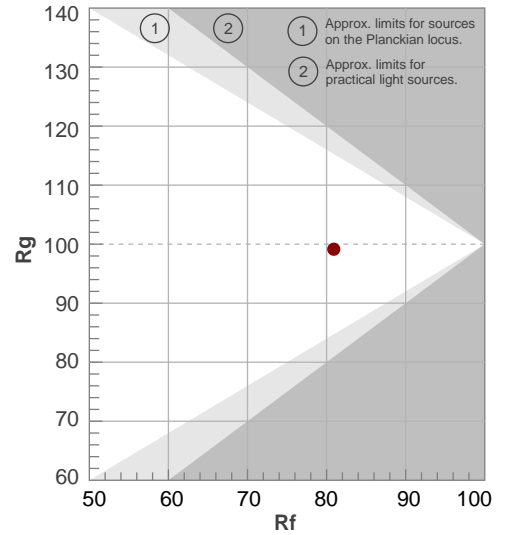

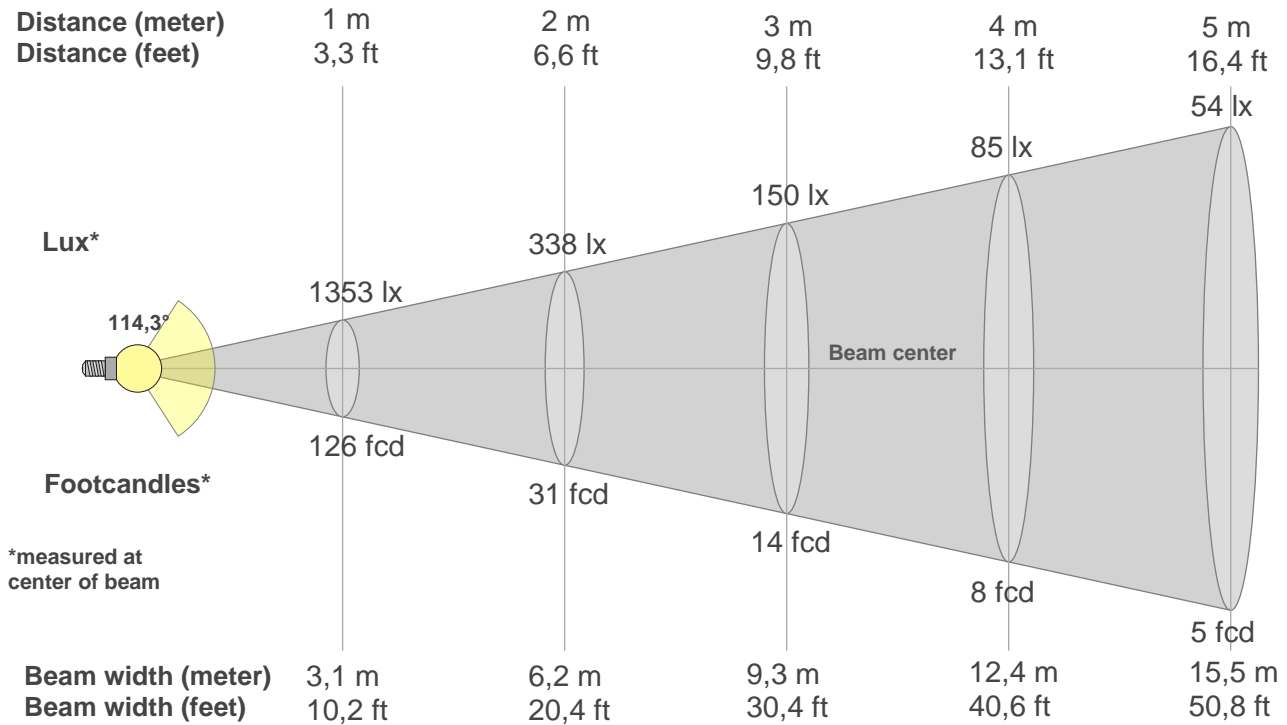

Beam intensities from 1-20m

1m	2m	3m	4m	5m	6m	7m	8m	9m	10m	11m	12m	13m	14m	15m	16m	17m	18m	19m	20m
3,3ft	6,6ft	9,8ft	13,1ft	16,4ft	19,7ft	23ft	26,2ft	29,5ft	32,8ft	36,1ft	39,4ft	42,7ft	45,9ft	49,2ft	52,5ft	55,8ft	59,1ft	62,3ft	65,6ft
1353lx	338lx	150lx	85lx	54lx	38lx	28lx	21lx	17lx	14lx	11lx	9lx	8lx	7lx	6lx	5lx	5lx	4lx	4lx	3lx
125,7fcd	31,4fcd	14fcd	7,9fcd	5fcd	3,5fcd	2,6fcd	2fcd	1,6fcd	1,3fcd	1fcd	0,9fcd	0,7fcd	0,6fcd	0,6fcd	0,5fcd	0,4fcd	0,4fcd	0,3fcd	0,3fcd

Intensities in 0° c-plane

0°	5°	10°	15°	20°	25°	30°	35°	40°	45°	50°	55°	60°	65°	70°	75°	80°	85°	90°	95°
1353	1352	1334	1306	1267	1217	1157	1087	1007	920	825	723	615	503	391	280	176	84	18	5
100%	100%	99%	97%	94%	90%	86%	80%	74%	68%	61%	53%	45%	37%	29%	21%	13%	6%	1%	0%

Intensities in 90° c-plane

0°	5°	10°	15°	20°	25°	30°	35°	40°	45°	50°	55°	60°	65°	70°	75°	80°	85°	90°	95°
1353	1352	1334	1306	1267	1217	1157	1087	1007	920	825	723	615	503	391	280	176	84	18	5
100%	100%	99%	97%	94%	90%	86%	80%	74%	68%	61%	53%	45%	37%	29%	21%	13%	6%	1%	0%

Intensities in 180° c-plane

0°	5°	10°	15°	20°	25°	30°	35°	40°	45°	50°	55°	60°	65°	70°	75°	80°	85°	90°	95°
1353	1352	1334	1306	1267	1217	1157	1087	1007	920	825	723	615	503	391	280	176	84	18	5
100%	100%	99%	97%	94%	90%	86%	80%	74%	68%	61%	53%	45%	37%	29%	21%	13%	6%	1%	0%

Intensities in 270° c-plane

0°	5°	10°	15°	20°	25°	30°	35°	40°	45°	50°	55°	60°	65°	70°	75°	80°	85°	90°	95°
1353	1352	1334	1306	1267	1217	1157	1087	1007	920	825	723	615	503	391	280	176	84	18	5
100%	100%	99%	97%	94%	90%	86%	80%	74%	68%	61%	53%	45%	37%	29%	21%	13%	6%	1%	0%

Beam angle 50%	Field angle 10%	Cutoff angle 2,5%	Intensity ratio in 120° cone	Intensity ratio in 90° cone
114,3°	164,3°	177,3°	76,8%	52,0%

iso-candela diagram

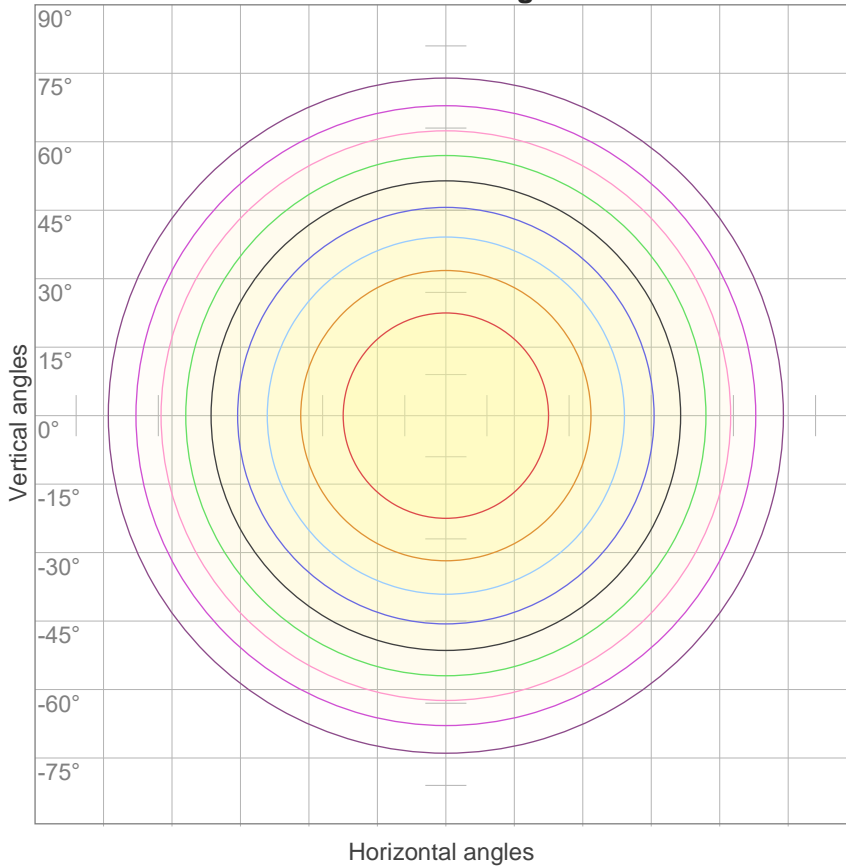

10%	135 cd
20%	271 cd
30%	406 cd
40%	541 cd
50%	676 cd
60%	812 cd
70%	947 cd
80%	1082 cd
90%	1217 cd

Conditions:

Number of c-planes: 12

Candela at center: 1353 cd

iso-lux diagram

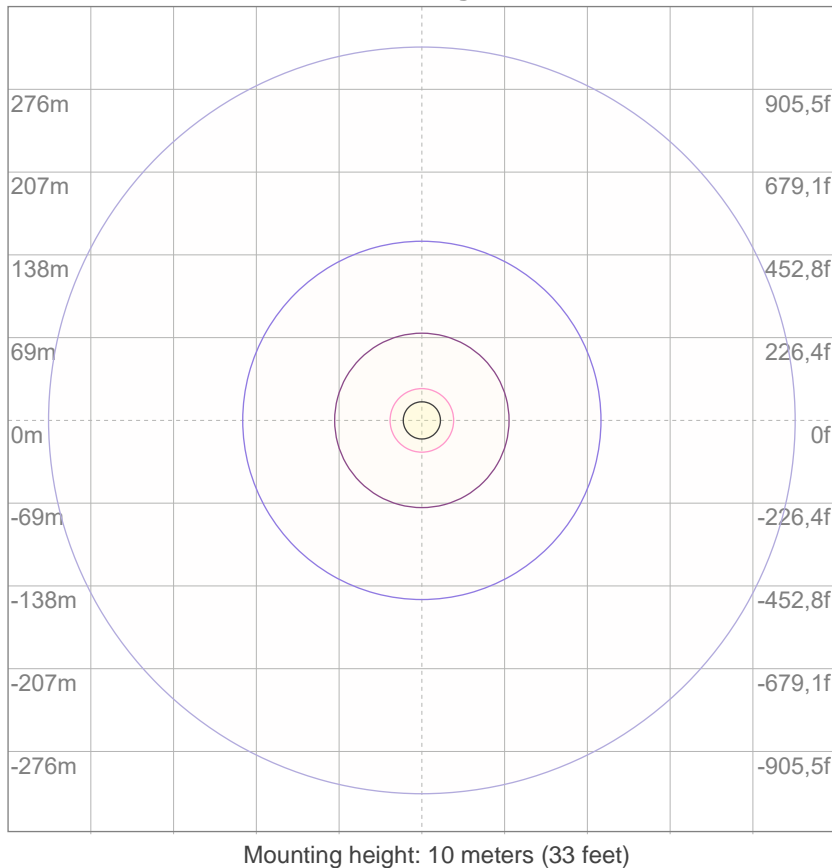

3%	0,406 lx
5%	0,676 lx
10%	1,35 lx
30%	4,06 lx
50%	6,76 lx

Conditions:

Number of c-planes: 12

Lux at center: 13,5 lx

Lux distribution on a surface when lamp is mounted at 10 meters from the surface.

Glare evaluation according to UGR

p Ceiling		70	70	50	50	30	70	70	50	50	30
p Walls		50	30	50	30	30	50	30	50	30	30
p Floor		20	20	20	20	20	20	20	20	20	20
Room size X Y		Viewing direction at right angles to lamp axis					Viewing direction parallel to lamp axis				
2H	2H	17,4	18,6	17,7	19,0	19,2	17,4	18,6	17,7	19,0	19,2
	3H	18,9	20,2	19,3	20,5	20,7	18,9	20,2	19,3	20,5	20,7
	4H	19,6	20,8	20,0	21,1	21,4	19,6	20,8	20,0	21,1	21,4
	6H	20,1	21,2	20,5	21,5	21,9	20,1	21,2	20,5	21,5	21,9
	8H	20,3	21,3	20,7	21,7	22,1	20,3	21,3	20,7	21,7	22,1
	12H	20,4	21,4	20,8	21,8	22,2	20,4	21,4	20,8	21,8	22,2
4H	2H	18,0	19,2	18,4	19,5	19,8	18,0	19,2	18,4	19,5	19,8
	3H	19,8	20,9	20,2	21,2	21,7	19,8	20,9	20,2	21,2	21,7
	4H	20,5	21,5	21,0	21,9	22,5	20,5	21,5	21,0	21,9	22,5
	6H	21,2	22,1	21,7	22,4	22,8	21,2	22,1	21,7	22,4	22,8
	8H	21,4	22,2	21,9	22,6	23,0	21,4	22,2	21,9	22,6	23,0
	12H	21,6	22,2	22,1	22,7	23,2	21,6	22,2	22,1	22,7	23,2
8H	4H	20,9	21,7	21,4	22,1	22,5	20,9	21,7	21,4	22,1	22,5
	6H	21,6	22,3	22,2	22,7	23,3	21,6	22,3	22,2	22,7	23,3
	8H	22,0	22,5	22,5	23,0	23,7	22,0	22,5	22,5	23,0	23,7
	12H	22,2	22,7	22,8	23,2	23,8	22,2	22,7	22,8	23,2	23,8
12H	4H	20,9	21,5	21,4	22,0	22,5	20,9	21,5	21,4	22,0	22,5
	6H	21,7	22,3	22,3	22,8	23,5	21,7	22,3	22,3	22,8	23,5
	8H	22,1	22,5	22,7	23,1	23,7	22,1	22,5	22,7	23,1	23,7
Variation of the observer position for the luminaire distance S											
S = 1.0H		0,1 / -0,1					0,1 / -0,1				
S = 1.5H		0,1 / -0,2					0,1 / -0,2				
S = 2.0H		0,4 / -0,4					0,4 / -0,4				
CIE 117-1995. Corrected glare indices referring to 4022 lm total luminous flux											

Coefficients of Utilization

Ceiling reflectance	80				70				50			30			10			0			
Wall reflectance	70	50	30	10	70	50	30	10	50	30	10	50	30	10	50	30	10	0			
Floor reflectance	20	20	20	20	20	20	20	20	20	20	20	20	20	20	20	20	20	20	20	20	0
RCR	(RCR: Room Cavity Ratio)																				
	Room Values are expressed as percentage of Lumens delivered to the task surface																				
0	119	119	119	119	116	116	116	116	111	111	111	106	106	106	101	101	101	99			
1	108	103	99	95	105	101	97	93	96	93	90	92	90	87	88	86	84	82			
2	98	90	83	77	95	88	81	76	84	79	74	81	76	72	77	74	70	68			
3	89	79	70	64	87	77	69	63	74	67	62	71	65	60	68	63	59	57			
4	82	69	61	54	79	68	60	53	65	58	52	63	57	52	61	55	51	49			
5	75	62	53	46	73	61	52	46	59	51	45	56	50	45	54	49	44	42			
6	69	56	47	40	67	55	46	40	53	45	40	51	44	39	49	43	39	37			
7	64	51	42	35	62	50	41	35	48	40	35	46	40	35	45	39	34	32			
8	60	46	37	32	58	45	37	31	44	36	31	43	36	31	41	35	31	29			
9	56	42	34	28	54	42	34	28	40	33	28	39	33	28	38	32	28	26			
10	52	39	31	26	51	38	31	26	37	30	25	36	30	25	35	29	25	23			

LAMPS (number of lamps)

Luminaire budgetary diagram

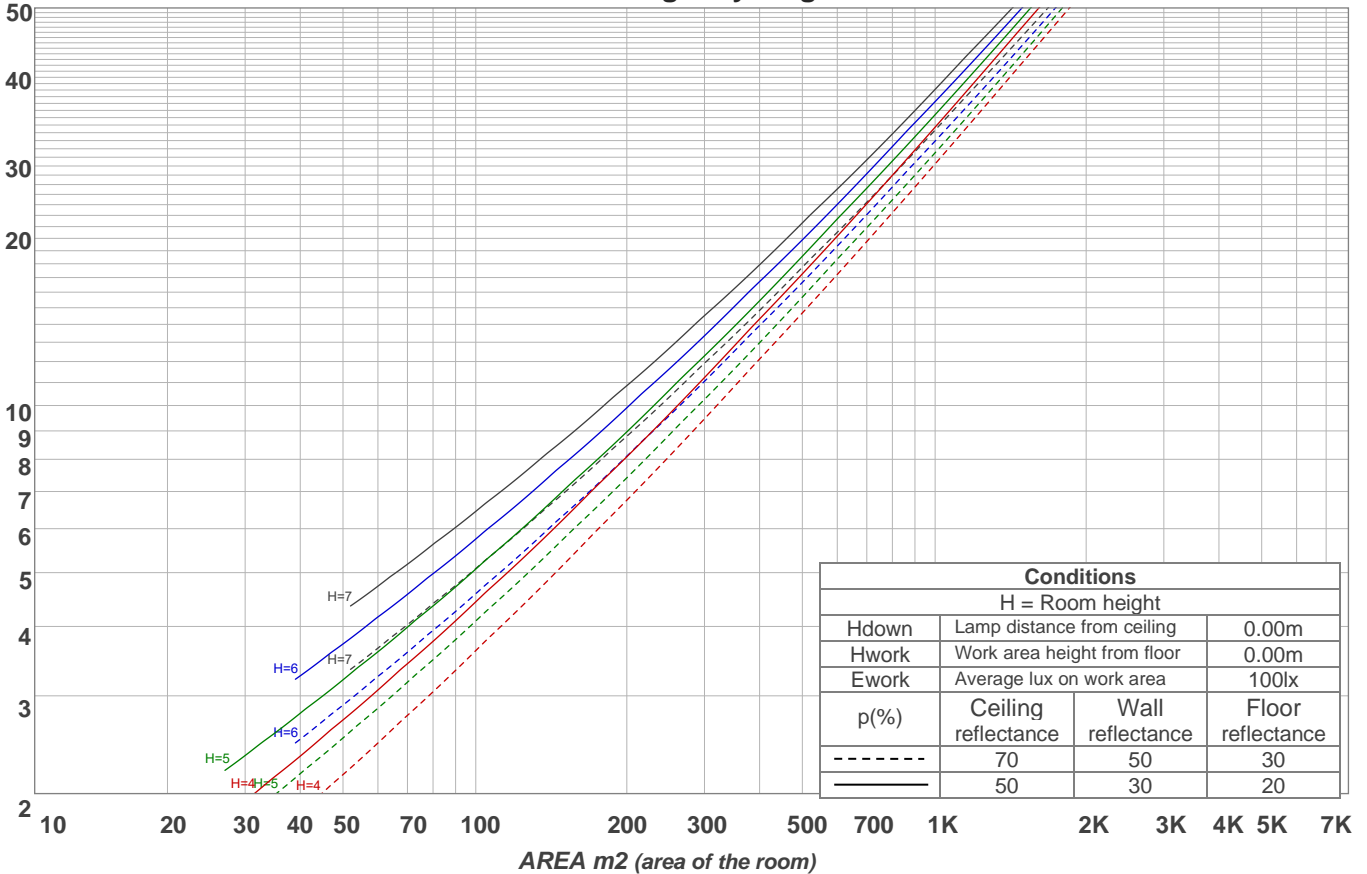

Zonal Lumen Summary

0°-10°	10°-20°	20°-30°	30°-40°	40°-50°	50°-60°	60°-70°	70°-80°	80°-90°
{LUM0-10}	368 lm	560 lm	679 lm	709 lm	645 lm	498 lm	297 lm	97,2 lm
90°-100°	100°-110°	110°-120°	120°-130°	130°-140°	140°-150°	150°-160°	160°-170°	170°-180°
8,84 lm	5,39 lm	5,61 lm	5,44 lm	5,19 lm	4,23 lm	3,32 lm	2,02 lm	0,713 lm

LCS table

BUG rating:	B2 U2 G1	
Forward light	Lumens	Lumens %
Low(0-30):	528,5	13,1%
Medium(30-60):	1016,4	25,3%
High(60-80):	397,3	9,9%
Very high(80-90):	48,7	1,2%
Back light		
Low(0-30):	528,5	13,1%
Medium(30-60):	1016,4	25,3%
High(60-80):	397,3	9,9%
Very high(80-90):	48,7	1,2%
Uplight		
Low(90-100):	8,9	0,2%
High(100-180):	31,9	0,8%

LCS graph

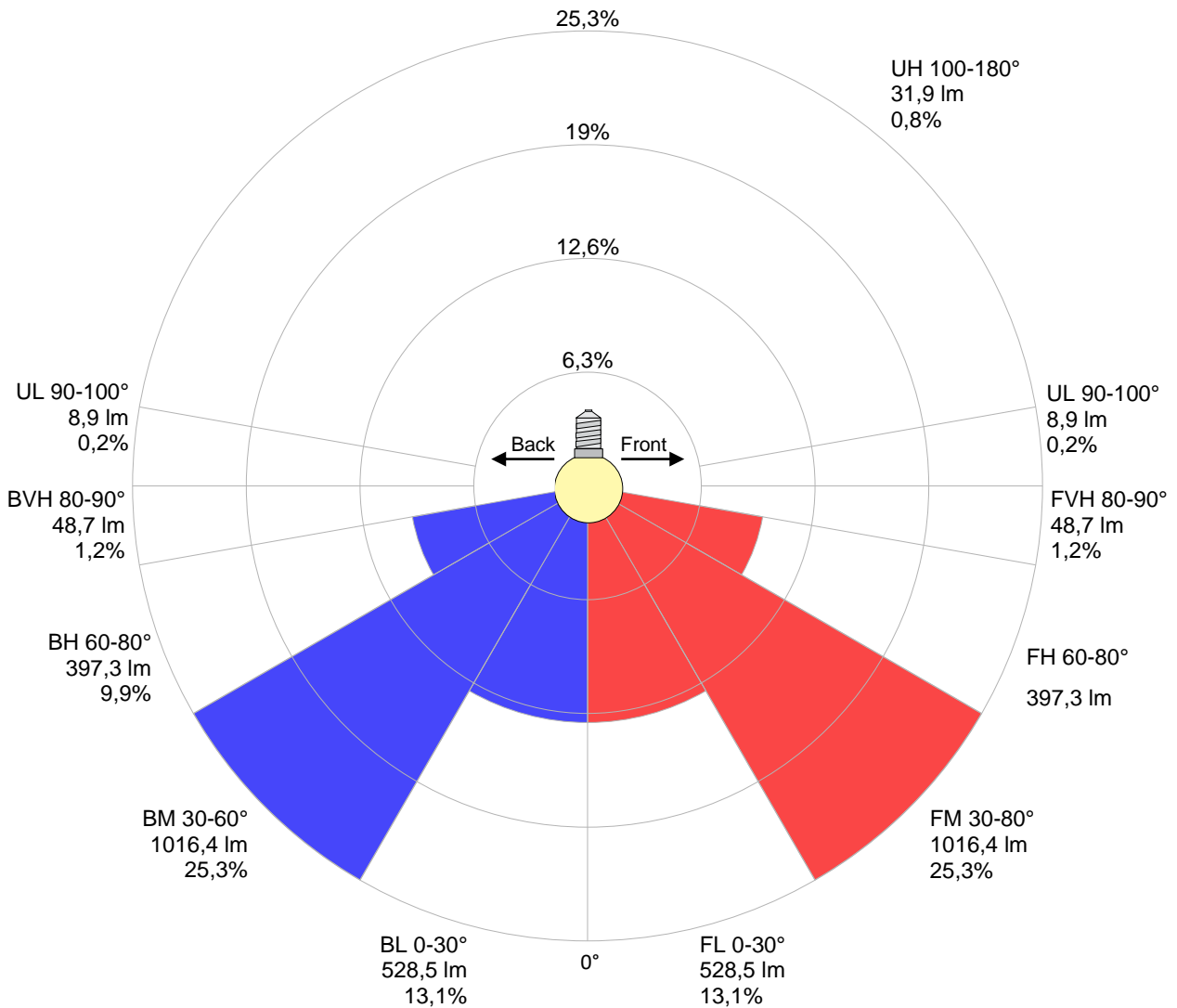

Warmup curve

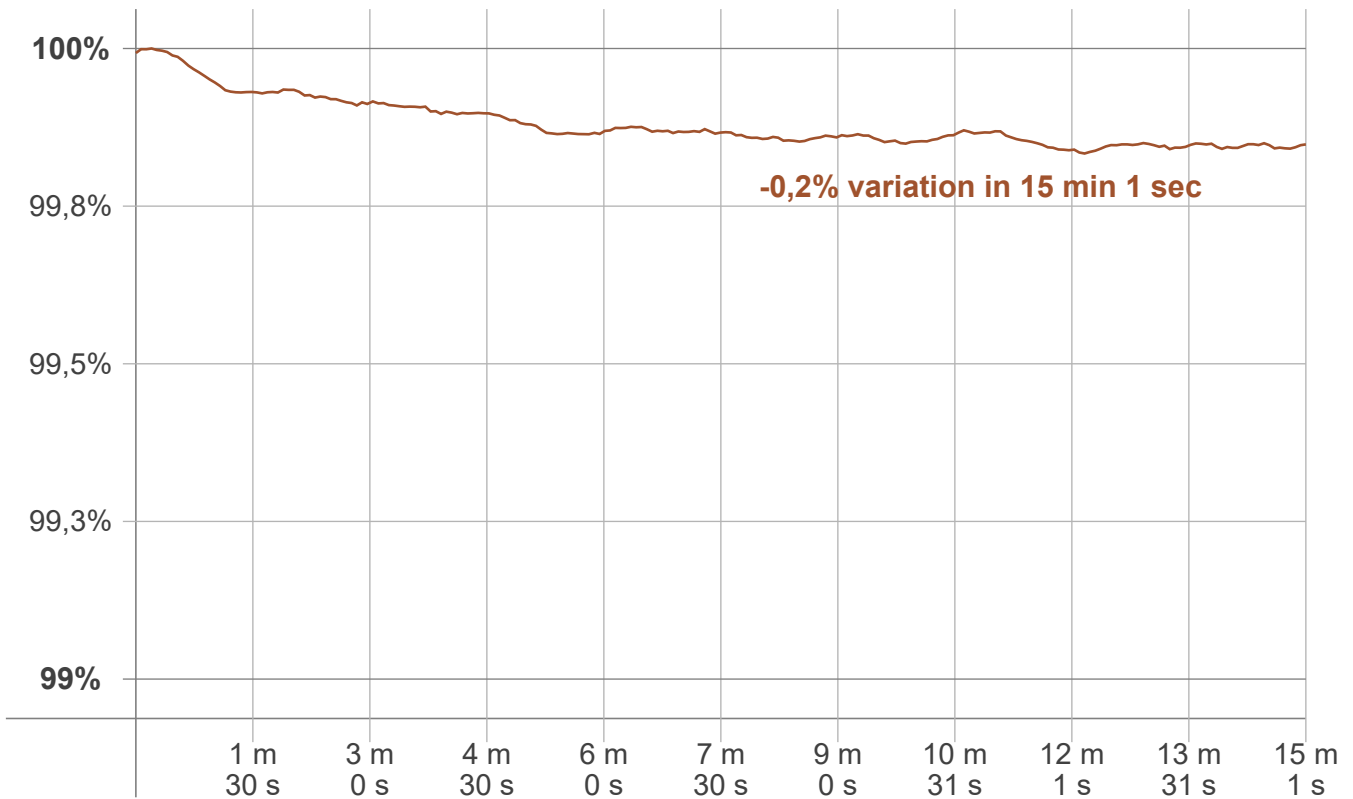

Warmup result

Warmup time:	Lamp stabilized in 15 min 1 sec
Warmup variation	-0,2%

Warmup conditions

Stable period:	15 min
Stable change max:	2,0%
Minimum time:	15 min

Color temperature change

CCT start	CCT change	CCT end
3995 K	+5 K	4000 K

Output change

Output start	Output change	Output end
4028 lm	-6 lm	4022 lm

Flicker curve (complete sampled flicker signal)



Flicker frame (frame of one flicker period)

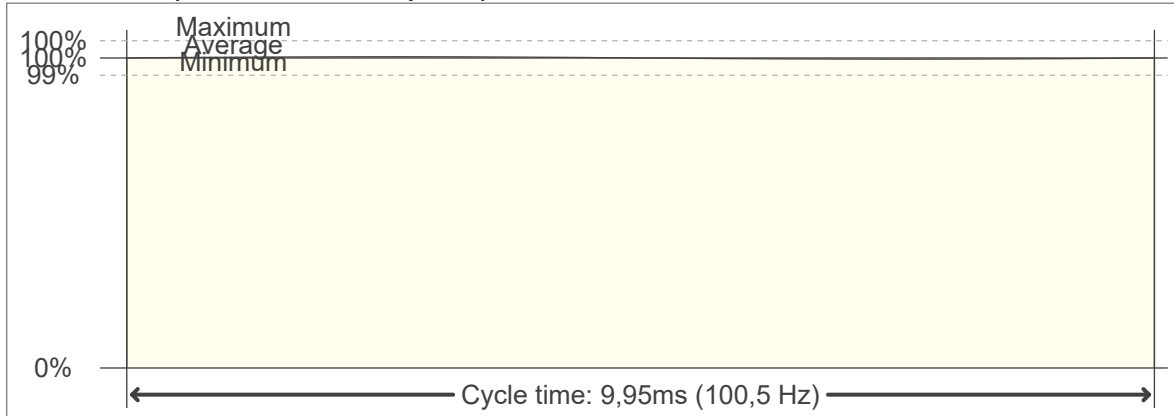

Flicker FFT (frequency scope of flicker curve)

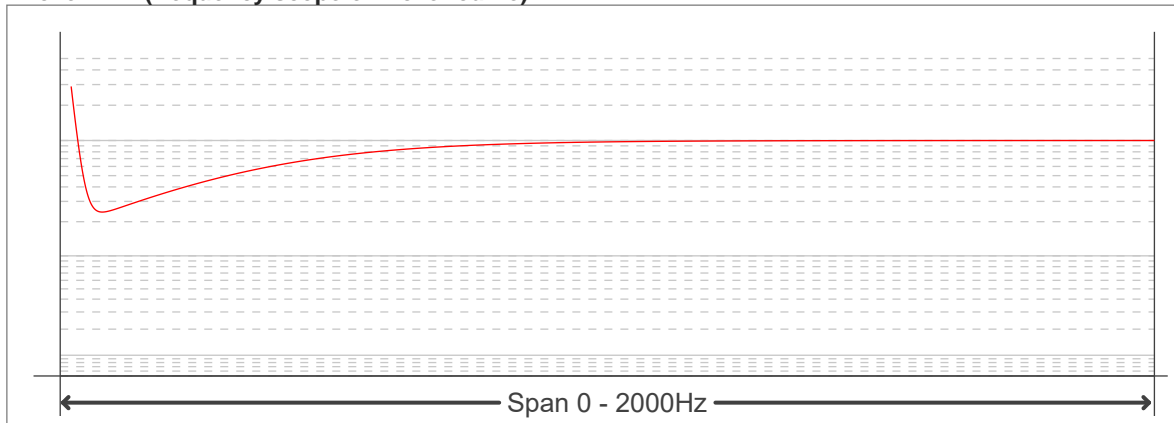

Flicker results:

Flicker frequency:		100,5 Hz	
Flicker index:	0	JA8/10 40Hz	0,02 %
Flicker percentage:	0,47 %	JA8/10 90Hz	0,04 %
SVM: (Visual flicker)	0,02	JA8/10 200Hz	0,46 %
PstLM	0,02	JA8/10 400Hz	0,47 %
Mp	0,02	JA8/10 1000Hz	0,47 %

Flicker conditions:

Sample rate:	20000 samples/second
--------------	----------------------