

Light efficiency:



Light quality:



Color temperature:



Output: 1305 lm

Peak: 442 cd

Power: 13,8 W

PF: 0,8

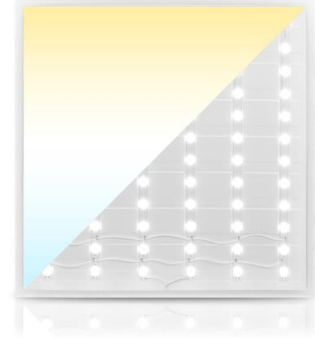

Tracking number: [VT241008-003737](#)

Product name:

**804367-6500K**

Item number:

**804367-6500K**

Date and time:

**8-10-2024 15:03:01**

Description:

**BACK-LIT LED PANEEL | ELTON |  
60x60CM | CCT | DIMBAAR | 40W**

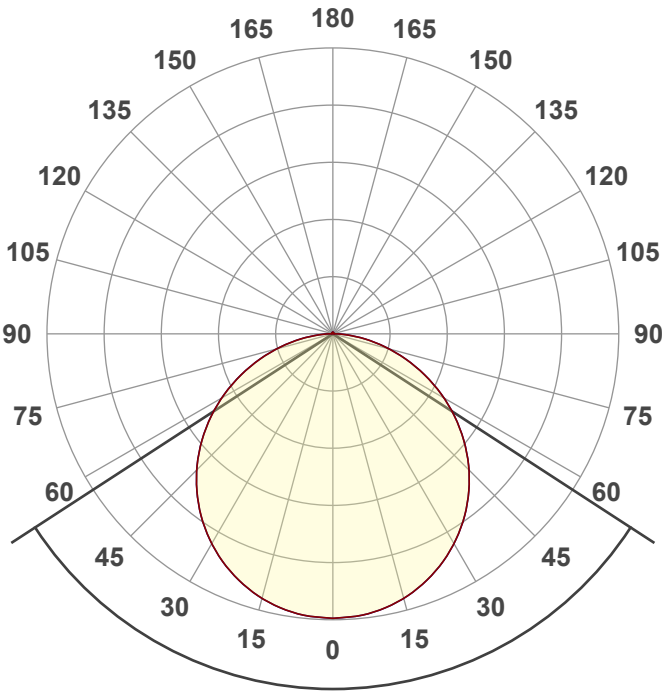

Beam angle

**113,9°**



CIE 1931  
x: 0,314  
y: 0,324

Spectra

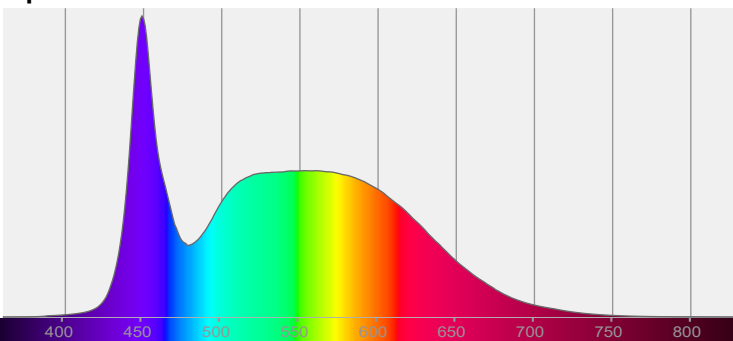

Power

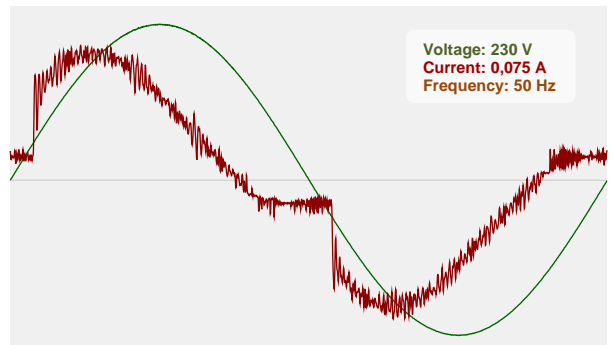

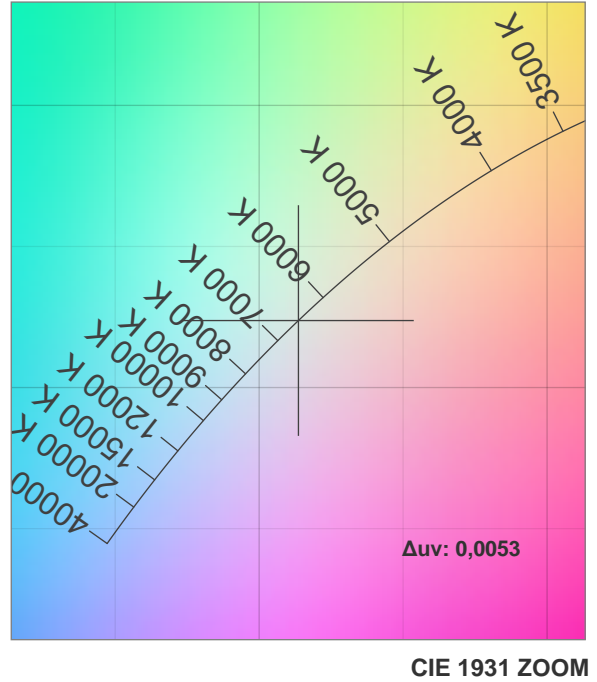
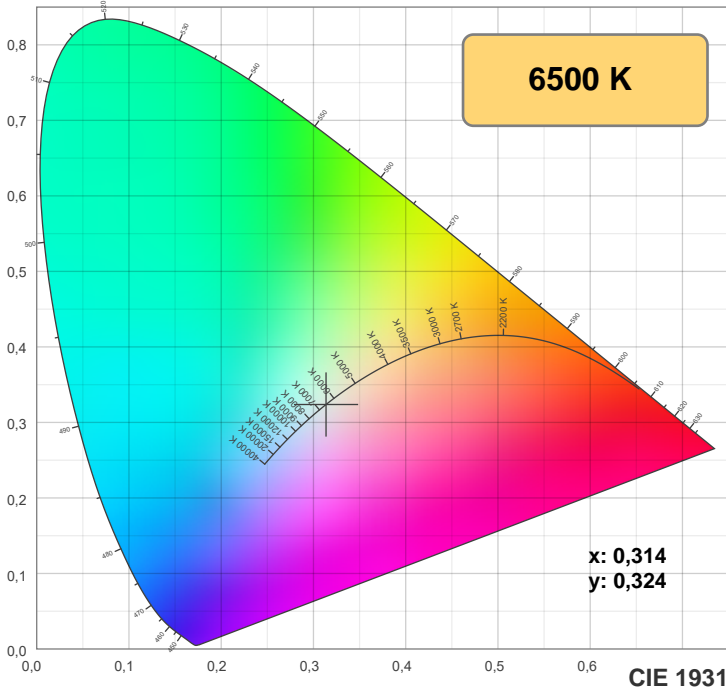

**TM30: 83,9**

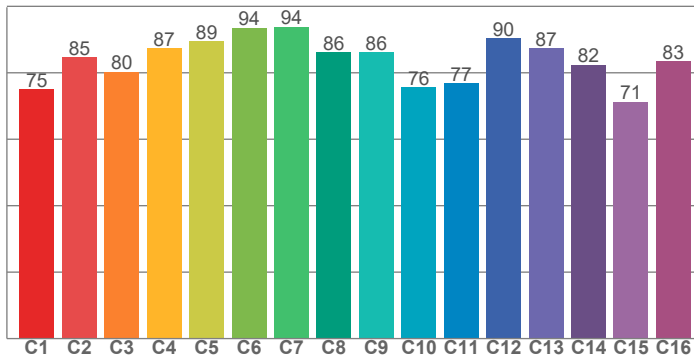

**CRI: 82,1 (R1-R8)**

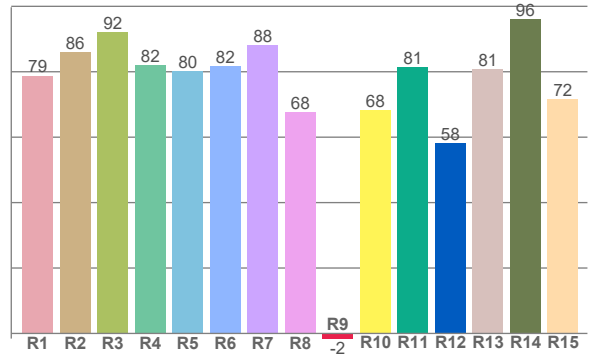

**CQS: 81,9**

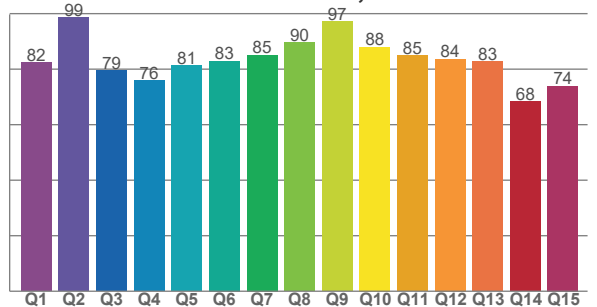

CRI R values, only R1-R8 are used to calculate final CRI value

R1	R2	R3	R4	R5	R6	R7	R8	R9	R10	R11	R12	R13	R14	R15
78,8	86,1	92,2	82,0	80,2	81,7	88,1	67,5	-1,6	68,2	81,5	58,2	80,7	96,0	71,7

TM30 C values, 16 binned values out of total of 99 C values

C1	C2	C3	C4	C5	C6	C7	C8	C9	C10	C11	C12	C13	C14	C15	C16
75,1	84,6	80,3	87,4	89,5	93,6	93,9	86,1	86,2	75,7	76,9	90,4	87,4	82,4	71,3	83,5

CQS Q values

Q1	Q2	Q3	Q4	Q5	Q6	Q7	Q8	Q9	Q10	Q11	Q12	Q13	Q14	Q15
82,5	98,5	79,5	75,9	81,3	82,9	85,1	89,6	97,2	87,9	84,9	83,7	82,8	68,4	73,9

**Color parameters**

Color temperature	Color rendering index	Red component	Color fidelity	Color gamut	Color quality scale	Color coordinate cie 1931	Color coordinate cie 1931	Color coordinate	Color coordinate	Color deviation from black body
CCT	CRI	CRI R9	TM30 Rf	TM30 Rg	CQS	x	y	u	v	Δuv
6500 K	82,1	-1,6	83,9	94,3	81,9	0,314	0,324	0,200	0,310	0,0053

**Rf 83,9**  
Fidelity index Rf

**Rg 94,3**  
Gamut index Rg

Hue Bin	R <sub>f</sub>	Shifts (%)	
		Chroma	Hue
1	75	-13%	-2%
2	85	-8%	5%
3	80	-5%	10%
4	87	0%	7%
5	89	0%	3%
6	94	1%	-2%
7	94	-2%	-3%
8	86	-8%	-1%
9	86	-9%	7%
10	76	-6%	14%
11	77	2%	15%
12	90	4%	4%
13	87	8%	-5%
14	82	4%	-10%
15	71	4%	-26%
16	83	-6%	-8%

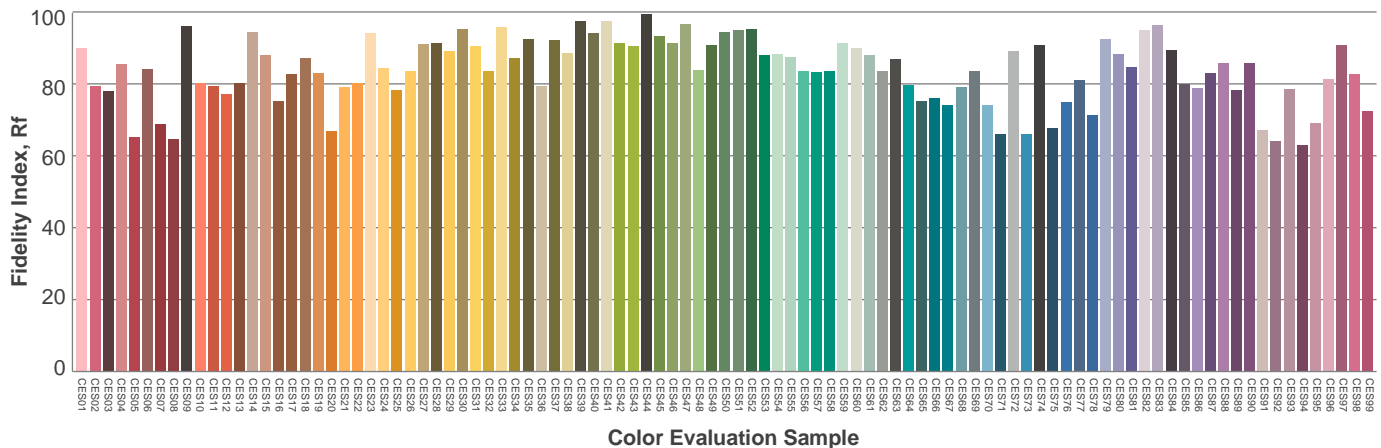
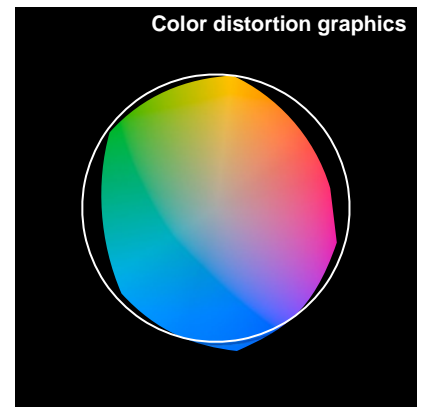
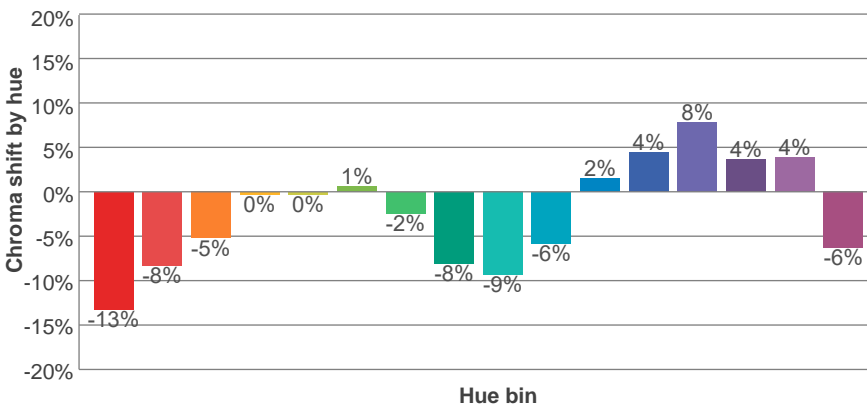
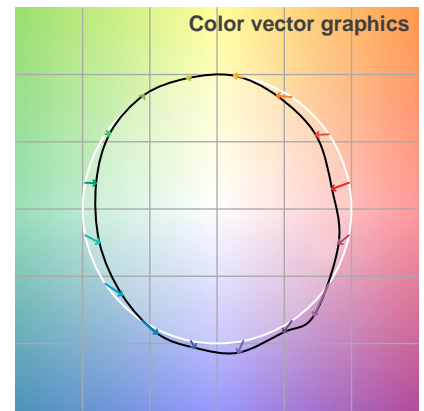
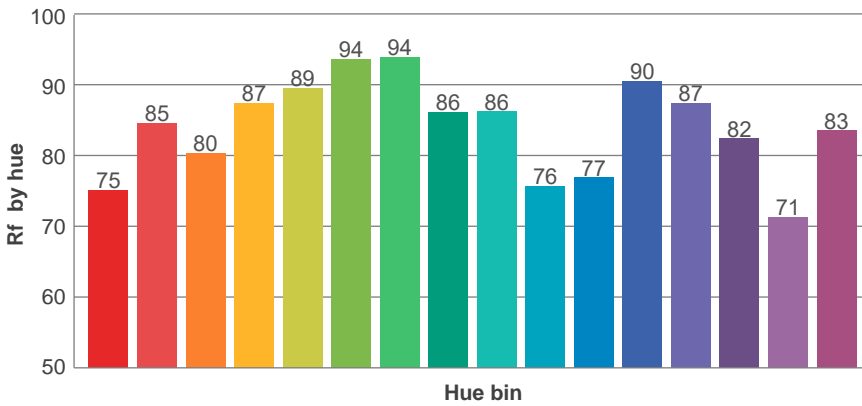
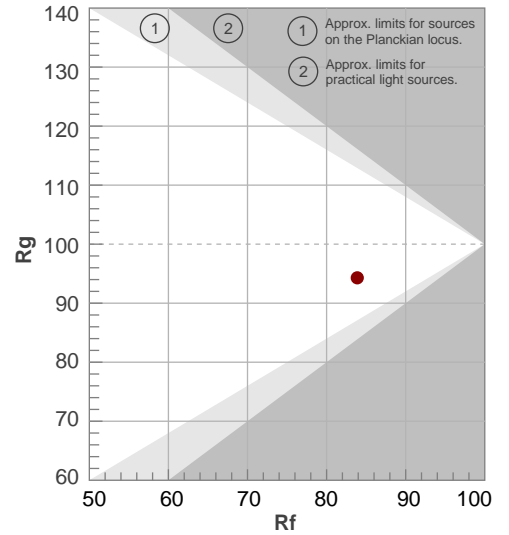

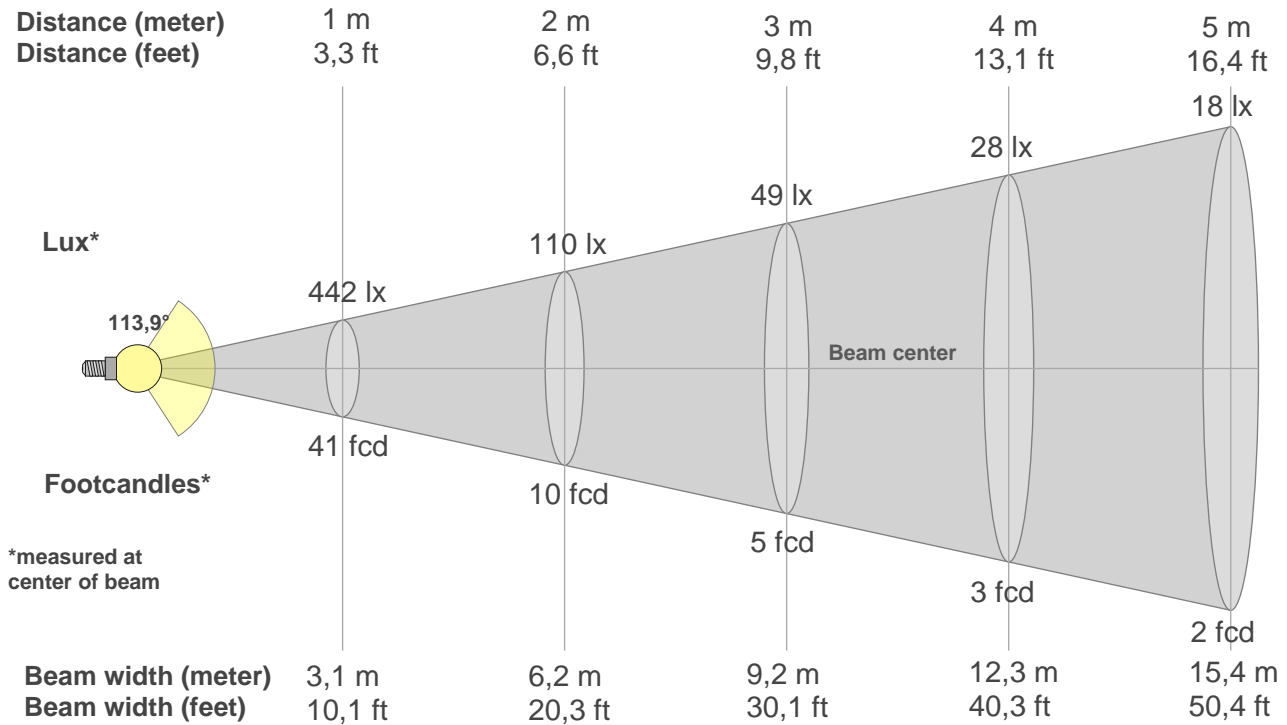

**Beam intensities from 1-20m**

1m	2m	3m	4m	5m	6m	7m	8m	9m	10m	11m	12m	13m	14m	15m	16m	17m	18m	19m	20m
3,3ft	6,6ft	9,8ft	13,1ft	16,4ft	19,7ft	23ft	26,2ft	29,5ft	32,8ft	36,1ft	39,4ft	42,7ft	45,9ft	49,2ft	52,5ft	55,8ft	59,1ft	62,3ft	65,6ft
442lx	110lx	49lx	28lx	18lx	12lx	9lx	7lx	5lx	4lx	4lx	3lx	3lx	2lx	2lx	2lx	2lx	1lx	1lx	1lx
41fcd	10,3fcd	4,6fcd	2,6fcd	1,6fcd	1,1fcd	0,8fcd	0,6fcd	0,5fcd	0,4fcd	0,3fcd	0,3fcd	0,2fcd	0,2fcd	0,2fcd	0,2fcd	0,1fcd	0,1fcd	0,1fcd	0,1fcd

**Intensities in 0° c-plane**

0°	5°	10°	15°	20°	25°	30°	35°	40°	45°	50°	55°	60°	65°	70°	75°	80°	85°	90°	95°
442	440	435	425	412	396	376	353	327	299	268	234	199	163	126	90	57	27	7	2
100%	100%	98%	96%	93%	90%	85%	80%	74%	68%	61%	53%	45%	37%	29%	20%	13%	6%	2%	0%

**Intensities in 90° c-plane**

0°	5°	10°	15°	20°	25°	30°	35°	40°	45°	50°	55°	60°	65°	70°	75°	80°	85°	90°	95°
442	440	435	425	412	396	376	353	327	299	268	234	199	163	126	90	57	27	7	2
100%	100%	98%	96%	93%	90%	85%	80%	74%	68%	61%	53%	45%	37%	29%	20%	13%	6%	2%	0%

**Intensities in 180° c-plane**

0°	5°	10°	15°	20°	25°	30°	35°	40°	45°	50°	55°	60°	65°	70°	75°	80°	85°	90°	95°
442	440	435	425	412	396	376	353	327	299	268	234	199	163	126	90	57	27	7	2
100%	100%	98%	96%	93%	90%	85%	80%	74%	68%	61%	53%	45%	37%	29%	20%	13%	6%	2%	0%

**Intensities in 270° c-plane**

0°	5°	10°	15°	20°	25°	30°	35°	40°	45°	50°	55°	60°	65°	70°	75°	80°	85°	90°	95°
442	440	435	425	412	396	376	353	327	299	268	234	199	163	126	90	57	27	7	2
100%	100%	98%	96%	93%	90%	85%	80%	74%	68%	61%	53%	45%	37%	29%	20%	13%	6%	2%	0%

Beam angle 50%	Field angle 10%	Cutoff angle 2,5%	Intensity ratio in 120° cone	Intensity ratio in 90° cone
113,9°	164,1°	177,7°	77,0%	52,2%

**iso-candela diagram**

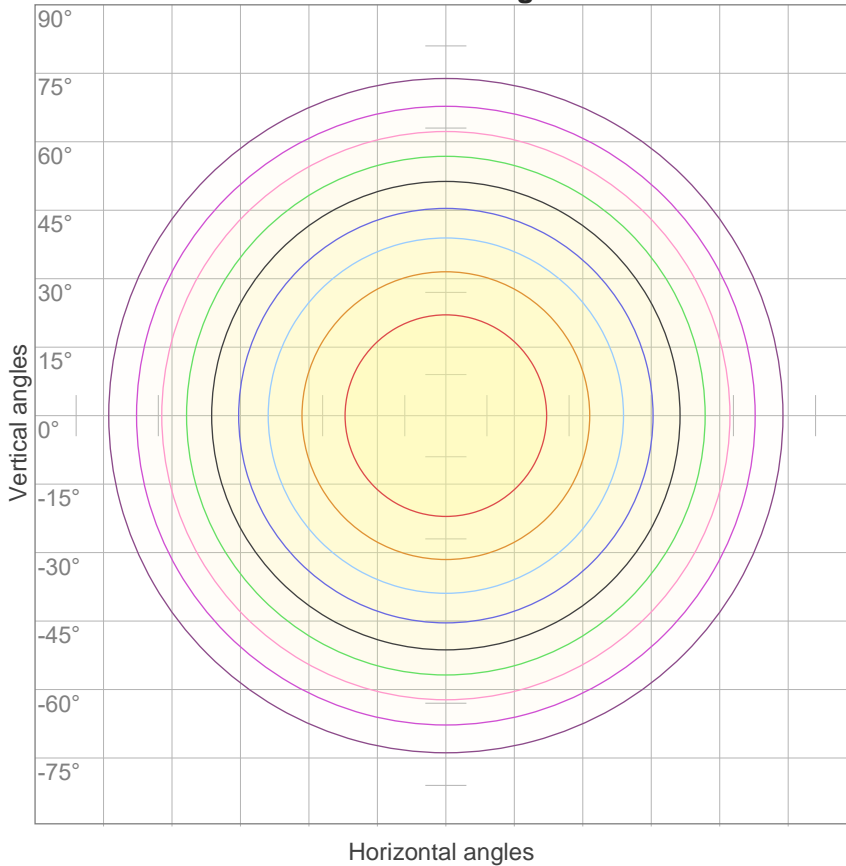

10%	44 cd
20%	88 cd
30%	132 cd
40%	177 cd
50%	221 cd
60%	265 cd
70%	309 cd
80%	353 cd
90%	397 cd

Conditions:

Number of c-planes: 12

Candela at center: 442 cd

**iso-lux diagram**

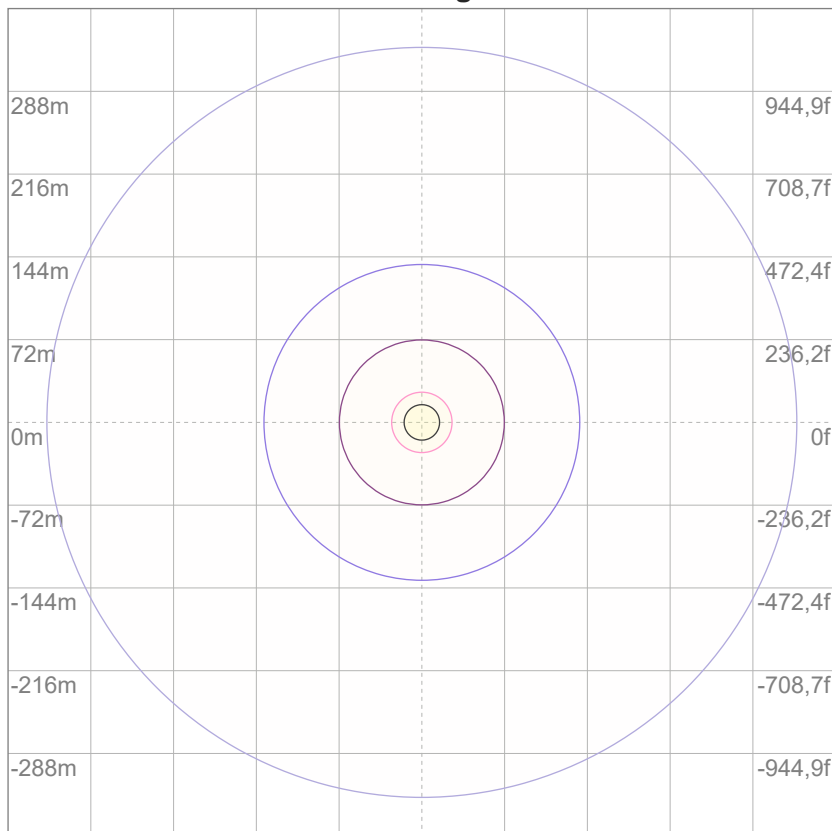

3%	0,132 lx
5%	0,221 lx
10%	0,442 lx
30%	1,32 lx
50%	2,21 lx

Conditions:

Number of c-planes: 12

Lux at center: 4,42 lx

*Lux distribution on a surface when lamp is mounted at 10 meters from the surface.*

Glare evaluation according to UGR

p Ceiling	70	70	50	50	30	70	70	50	50	30	
p Walls	50	30	50	30	30	50	30	50	30	30	
p Floor	20	20	20	20	20	20	20	20	20	20	
Room size X Y	Viewing direction at right angles to lamp axis					Viewing direction parallel to lamp axis					
2H	2H	13,5	14,7	13,7	15,0	15,3	13,5	14,7	13,7	15,0	15,3
	3H	15,0	16,2	15,4	16,5	16,8	15,0	16,2	15,4	16,5	16,8
	4H	15,6	16,8	16,0	17,1	17,4	15,6	16,8	16,0	17,1	17,4
	6H	16,2	17,3	16,5	17,5	17,9	16,2	17,3	16,5	17,5	17,9
	8H	16,4	17,4	16,7	17,7	18,1	16,4	17,4	16,7	17,7	18,1
	12H	16,5	17,5	16,8	17,8	18,3	16,5	17,5	16,8	17,8	18,3
4H	2H	14,1	15,3	14,5	15,6	15,9	14,1	15,3	14,5	15,6	15,9
	3H	15,9	16,9	16,3	17,3	17,7	15,9	16,9	16,3	17,3	17,7
	4H	16,6	17,5	17,1	18,0	18,5	16,6	17,5	17,1	18,0	18,5
	6H	17,2	18,1	17,7	18,5	18,9	17,2	18,1	17,7	18,5	18,9
	8H	17,4	18,2	18,0	18,6	19,0	17,4	18,2	18,0	18,6	19,0
	12H	17,6	18,3	18,1	18,7	19,2	17,6	18,3	18,1	18,7	19,2
8H	4H	16,9	17,7	17,4	18,1	18,5	16,9	17,7	17,4	18,1	18,5
	6H	17,7	18,3	18,2	18,8	19,3	17,7	18,3	18,2	18,8	19,3
	8H	18,0	18,6	18,5	19,1	19,7	18,0	18,6	18,5	19,1	19,7
	12H	18,3	18,7	18,8	19,2	19,9	18,3	18,7	18,8	19,2	19,9
12H	4H	16,9	17,6	17,4	18,0	18,5	16,9	17,6	17,4	18,0	18,5
	6H	17,8	18,3	18,3	18,8	19,5	17,8	18,3	18,3	18,8	19,5
	8H	18,1	18,6	18,7	19,1	19,7	18,1	18,6	18,7	19,1	19,7
Variation of the observer position for the luminaire distance S											
S = 1.0H	0,1 / -0,1					0,1 / -0,1					
S = 1.5H	0,1 / -0,2					0,1 / -0,2					
S = 2.0H	0,4 / -0,4					0,4 / -0,4					
CIE 117-1995. Corrected glare indices referring to 1305 lm total luminous flux											

**Coefficients of Utilization**

Ceiling reflectance	80				70				50			30			10			0			
Wall reflectance	70	50	30	10	70	50	30	10	50	30	10	50	30	10	50	30	10	0			
Floor reflectance	20	20	20	20	20	20	20	20	20	20	20	20	20	20	20	20	20	20	20	20	0
RCR	(RCR: Room Cavity Ratio)																				
	Room Values are expressed as percentage of Lumens delivered to the task surface																				
0	119	119	119	119	116	116	116	116	111	111	111	106	106	106	101	101	101	99			
1	108	103	99	95	105	101	97	93	96	93	90	92	90	87	89	86	84	82			
2	98	90	83	77	95	88	81	76	84	79	74	81	76	72	77	74	70	68			
3	89	79	70	64	87	77	69	63	74	67	62	71	65	61	68	63	59	57			
4	82	70	61	54	79	68	60	53	66	58	53	63	57	52	61	55	51	49			
5	75	62	53	46	73	61	52	46	59	51	45	57	50	45	55	49	44	42			
6	69	56	47	40	67	55	46	40	53	45	40	51	44	39	49	43	39	37			
7	64	51	42	35	62	50	41	35	48	41	35	47	40	35	45	39	34	32			
8	60	46	38	32	58	45	37	31	44	37	31	43	36	31	41	35	31	29			
9	56	42	34	28	54	42	34	28	40	33	28	39	33	28	38	32	28	26			
10	52	39	31	26	51	38	31	26	37	30	25	36	30	25	35	29	25	23			

LAMPS (number of lamps)

**Luminaire budgetary diagram**

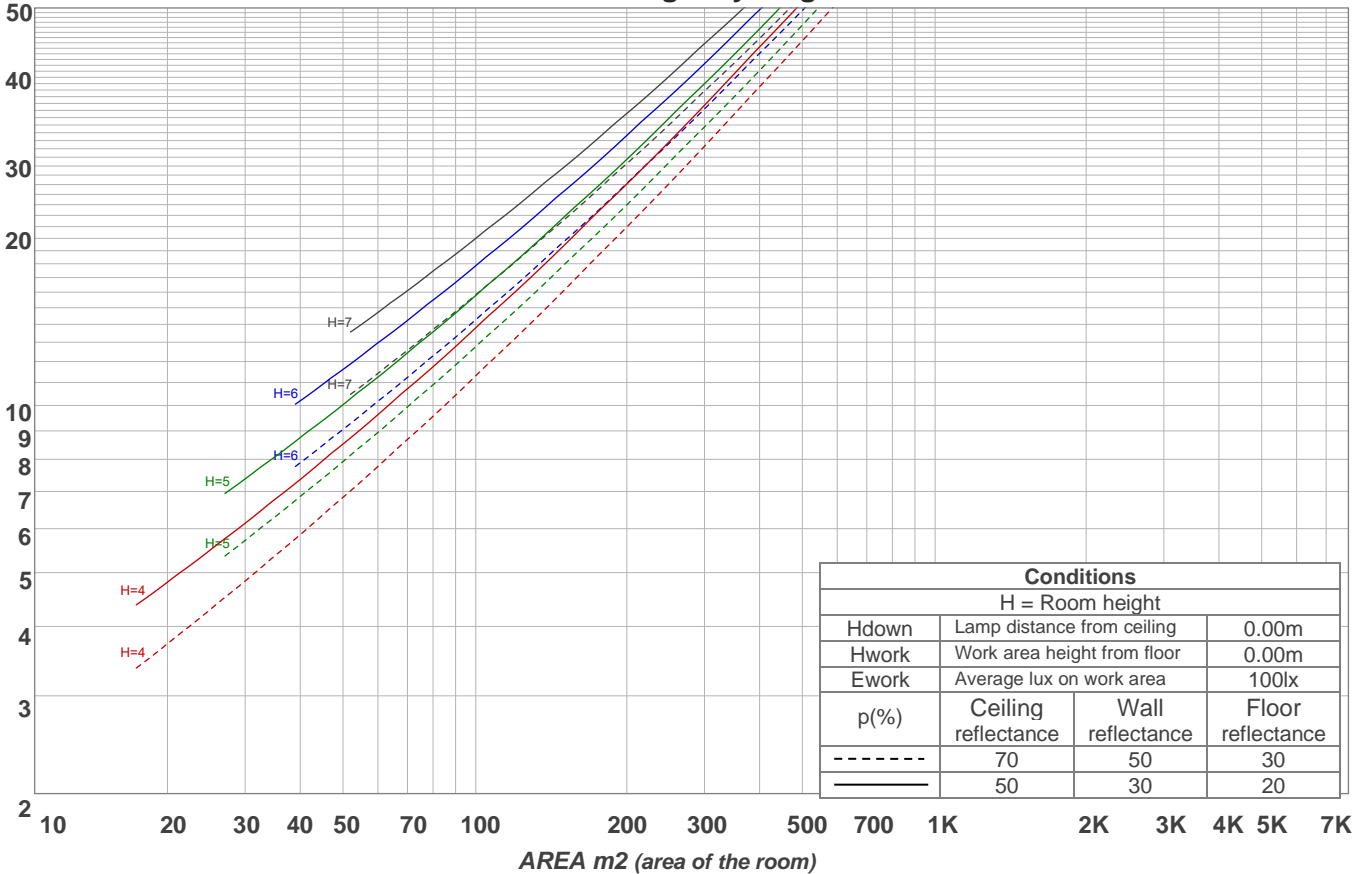

**Zonal Lumen Summary**

0°-10°	10°-20°	20°-30°	30°-40°	40°-50°	50°-60°	60°-70°	70°-80°	80°-90°
{LUM0-10}	120 lm	182 lm	221 lm	230 lm	209 lm	161 lm	95,8 lm	31,3 lm
90°-100°	100°-110°	110°-120°	120°-130°	130°-140°	140°-150°	150°-160°	160°-170°	170°-180°
2,42 lm	1,60 lm	1,65 lm	1,64 lm	1,49 lm	1,29 lm	0,977 lm	0,650 lm	0,225 lm

LCS table

BUG rating:	B1 U1 G1	
<b>Forward light</b>	Lumens	Lumens %
Low(0-30):	172,1	13,2%
Medium(30-60):	330,3	25,3%
High(60-80):	128,5	9,8%
Very high(80-90):	15,7	1,2%
<b>Back light</b>		
Low(0-30):	172,1	13,2%
Medium(30-60):	330,3	25,3%
High(60-80):	128,5	9,8%
Very high(80-90):	15,7	1,2%
<b>Uplight</b>		
Low(90-100):	2,6	0,2%
High(100-180):	9,5	0,7%

LCS graph

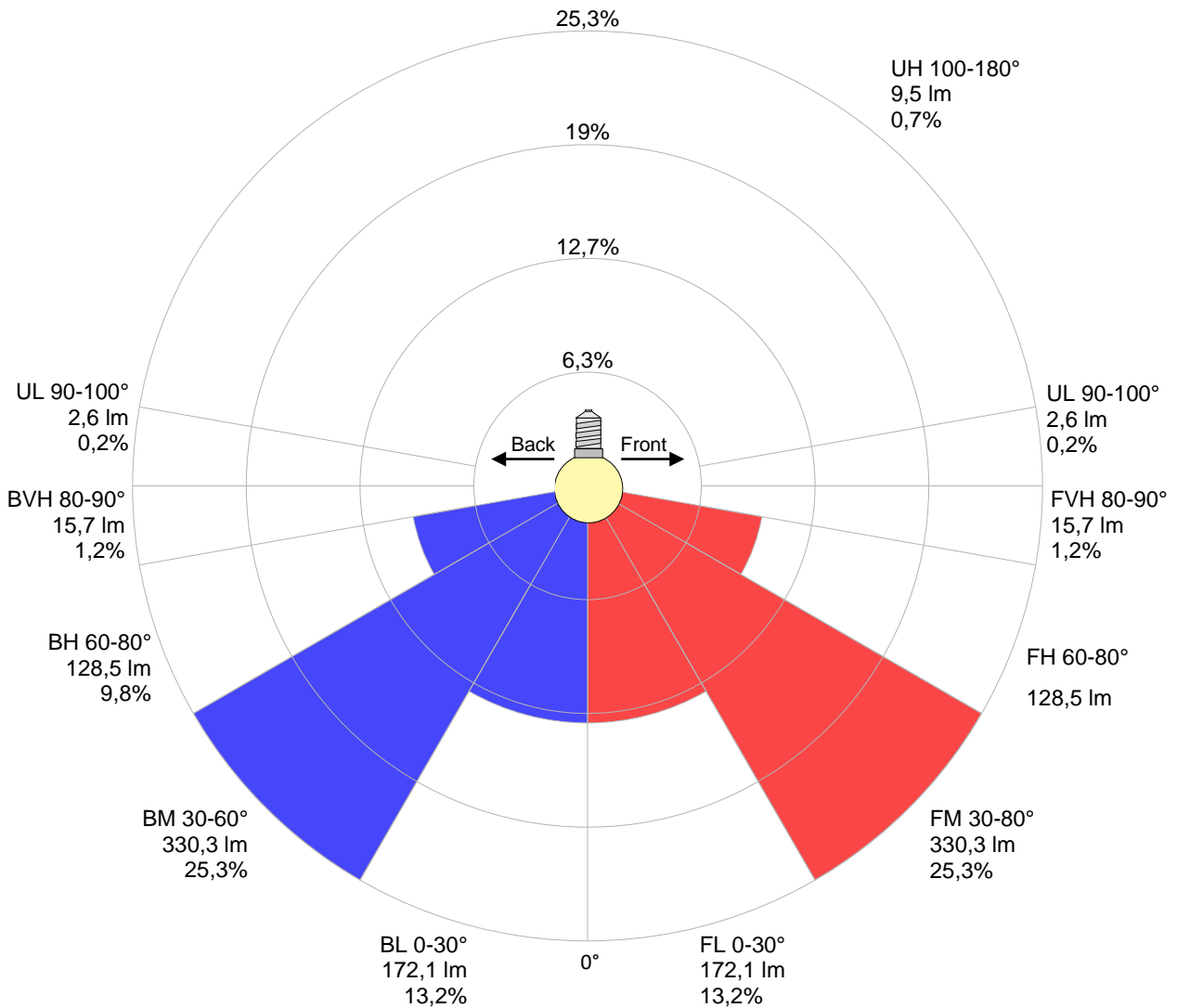

**Warmup curve**

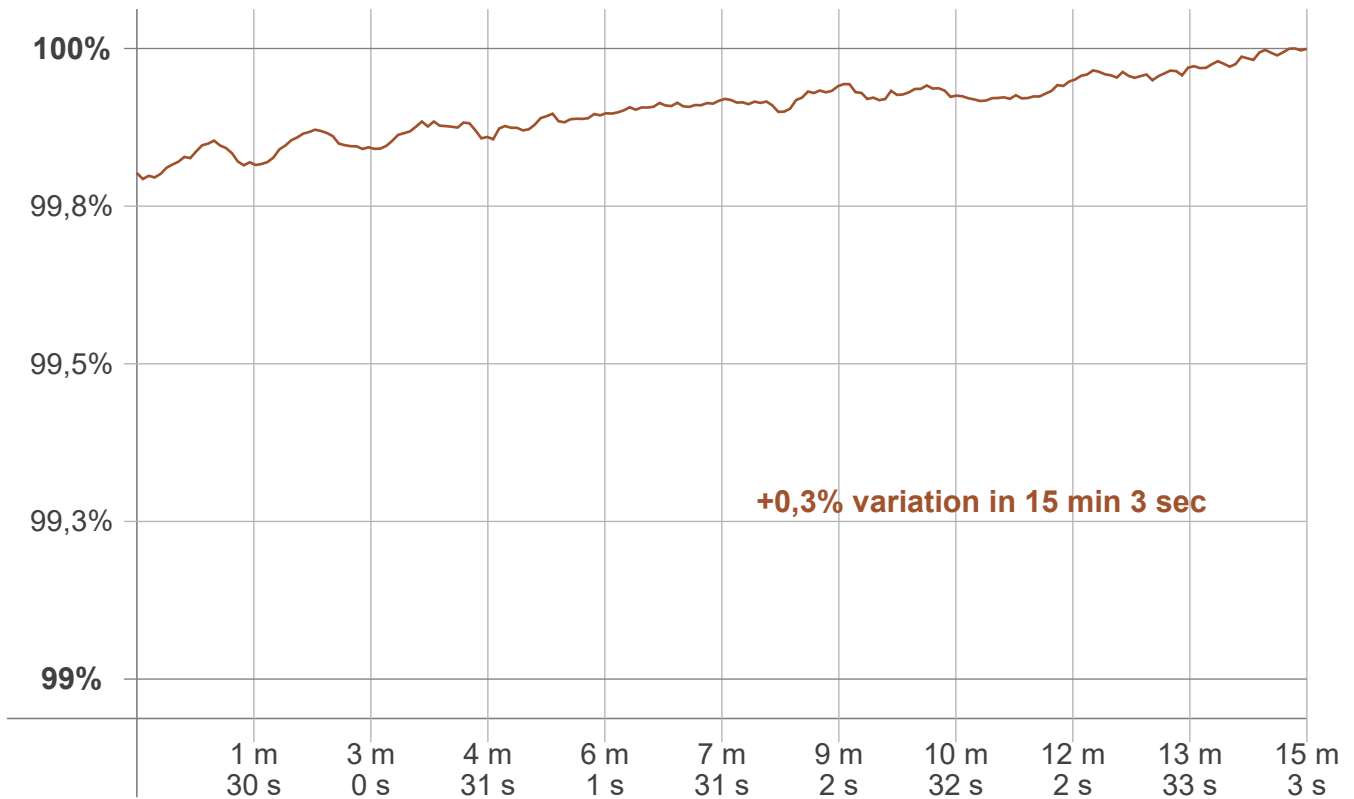

**Warmup result**

<b>Warmup time:</b>	<b>Lamp stabilized in 15 min 3 sec</b>
<b>Warmup variation</b>	<b>+0,3%</b>

**Warmup conditions**

<b>Stable period:</b>	<b>15 min</b>
<b>Stable change max:</b>	<b>2,0%</b>
<b>Minimum time:</b>	<b>15 min</b>

**Color temperature change**

CCT start	CCT change	CCT end
6500 K	0 K	6500 K

**Output change**

Output start	Output change	Output end
1303 lm	+3 lm	1305 lm

**Flicker curve (complete sampled flicker signal)**



**Flicker frame (frame of one flicker period)**

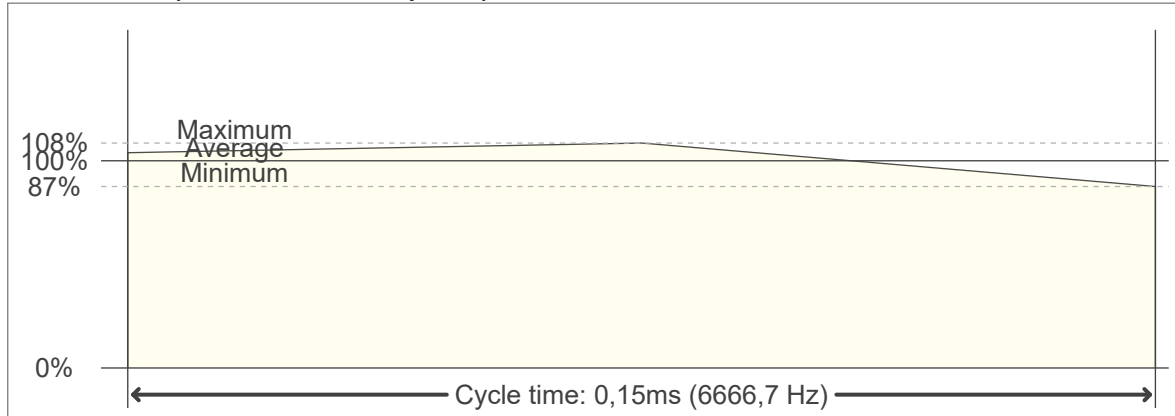

**Flicker FFT (frequency scope of flicker curve)**

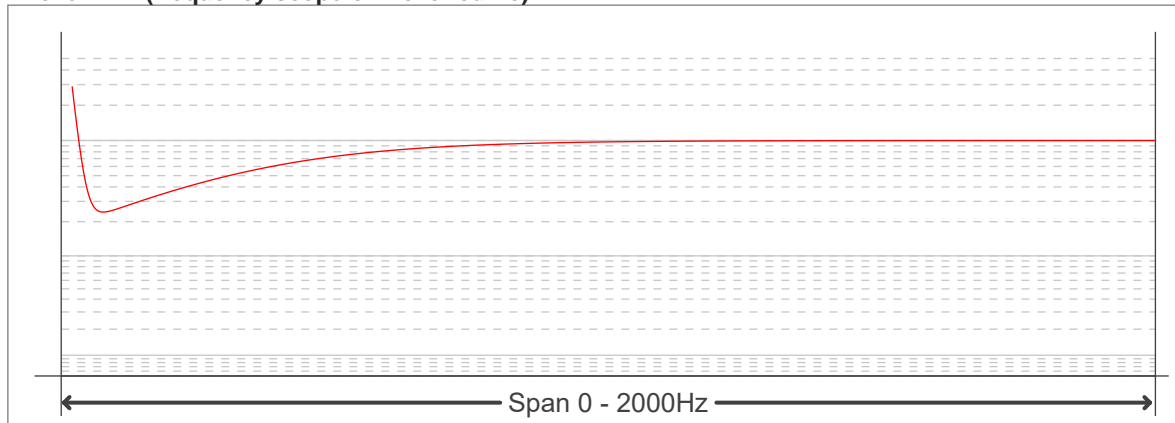

**Flicker results:**

Flicker frequency:		6666,67 Hz	
Flicker index:	0,04	JA8/10 40Hz	0,3 %
Flicker percentage:	26,55 %	JA8/10 90Hz	0,68 %
SVM: (Visual flicker)	0,01	JA8/10 200Hz	1,74 %
PstLM	0,02	JA8/10 400Hz	2,78 %
Mp	0,06	JA8/10 1000Hz	6,28 %

**Flicker conditions:**

Sample rate:	20000 samples/second
--------------	----------------------