

Light efficiency:



Light quality:



Color temperature:



Output: 3272 lm

Peak: 1101 cd

Power: 35,4 W

PF: 0,98

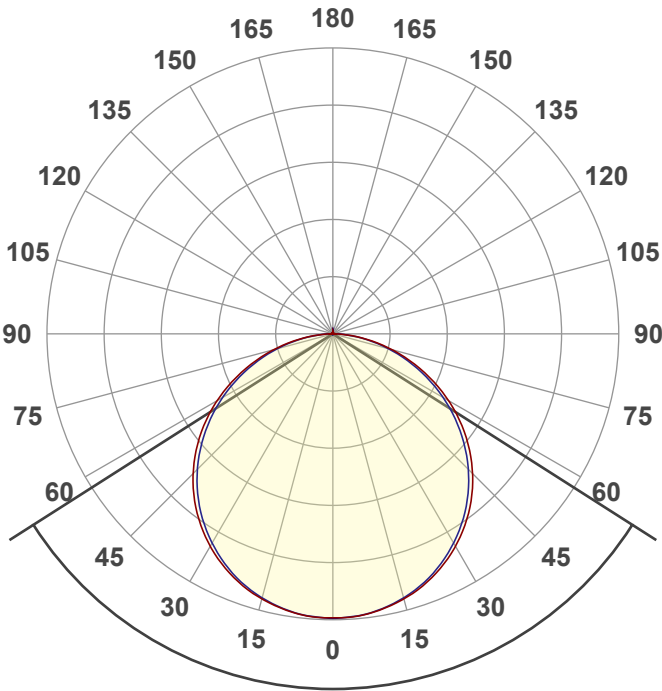

Tracking number: [VT240926-008325](#)

Product name:

804848-4000K

Item number:

804848-4000K

Date and time:

26-9-2024 16:07:03

Description:

BACK-LIT LED PANEEL | BRISTOL | 120x30 | 40W

Beam angle

114,9°



CIE 1931
x: 0,437
y: 0,404

Spectra

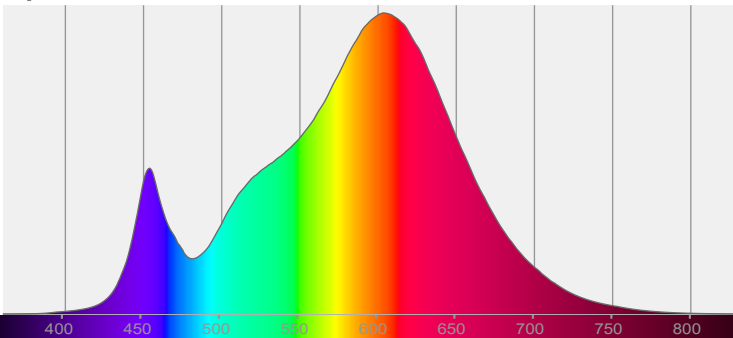

Power

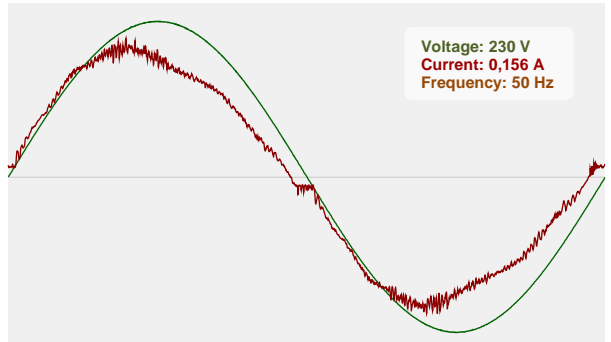

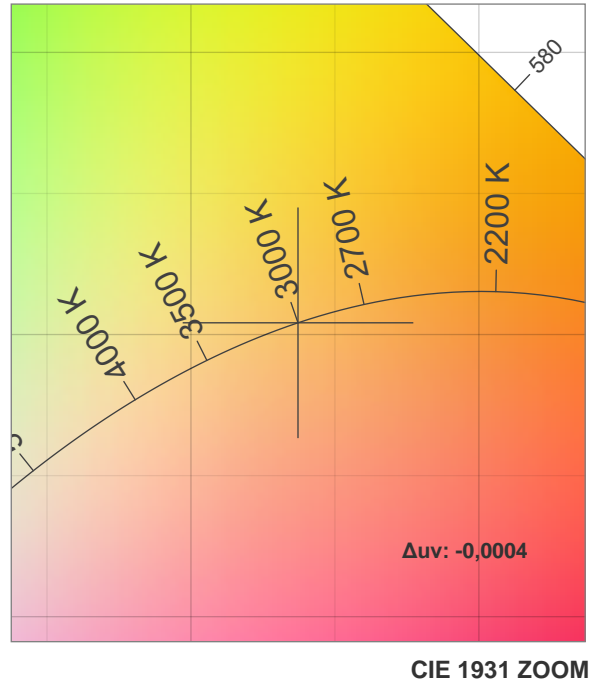
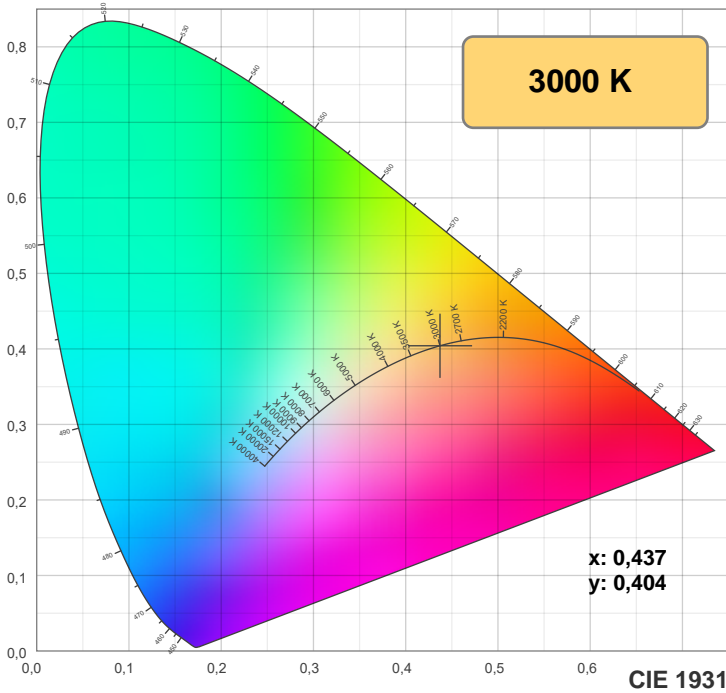

TM-30: 85,3

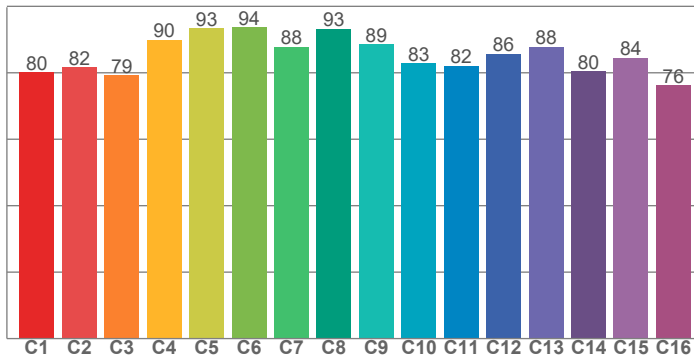

CRI: 83,2 (R1-R8)

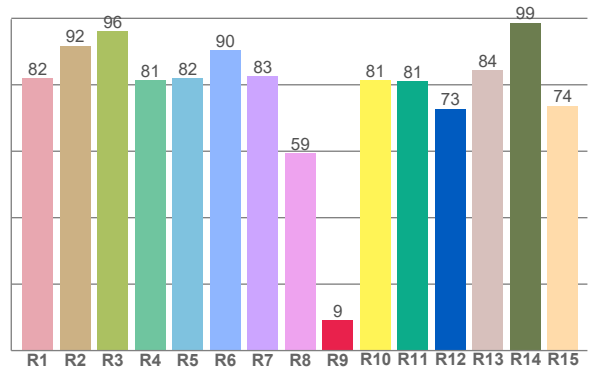

CQS: 82,4

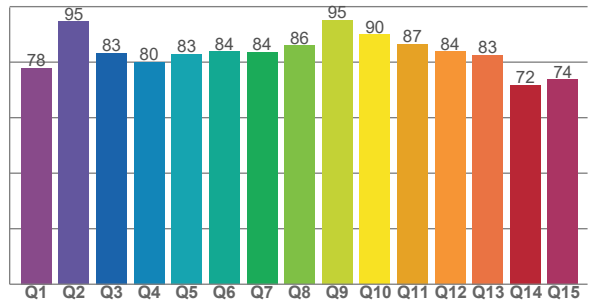

CRI R values, only R1-R8 are used to calculate final CRI value

R1	R2	R3	R4	R5	R6	R7	R8	R9	R10	R11	R12	R13	R14	R15
81,9	91,8	96,2	81,4	82,0	90,4	82,6	59,4	9,2	81,3	81,1	72,8	84,4	98,7	73,7

TM30 C values, 16 binned values out of total of 99 C values

C1	C2	C3	C4	C5	C6	C7	C8	C9	C10	C11	C12	C13	C14	C15	C16
80,1	81,7	79,3	90,0	93,4	93,6	87,8	93,2	88,6	82,9	82,2	85,7	87,8	80,4	84,5	76,2

CQS Q values

Q1	Q2	Q3	Q4	Q5	Q6	Q7	Q8	Q9	Q10	Q11	Q12	Q13	Q14	Q15
78,0	94,7	83,3	80,0	83,0	83,9	83,7	86,0	95,2	90,0	86,6	83,8	82,6	71,7	73,8

Color parameters

Color temperature	Color rendering index	Red component	Color fidelity	Color gamut	Color quality scale	Color coordinate cie 1931	Color coordinate cie 1931	Color coordinate	Color coordinate	Color deviation from black body
CCT	CRI	CRI R9	TM30 Rf	TM30 Rg	CQS	x	y	u	v	Δuv
3000 K	83,2	9,2	85,3	95,7	82,4	0,437	0,404	0,251	0,348	-0,0004

Rf 85,3
Fidelity index Rf

Rg 95,7
Gamut index Rg

Hue Bin	R _f	Shifts (%)	
		Chroma	Hue
1	80	-11%	0%
2	82	-8%	7%
3	79	-3%	11%
4	90	0%	5%
5	93	2%	4%
6	94	2%	-2%
7	88	-4%	-6%
8	93	-4%	-1%
9	89	-6%	4%
10	83	-4%	10%
11	82	0%	13%
12	86	6%	3%
13	88	5%	-7%
14	80	5%	-15%
15	84	-3%	-9%
16	76	-9%	-16%

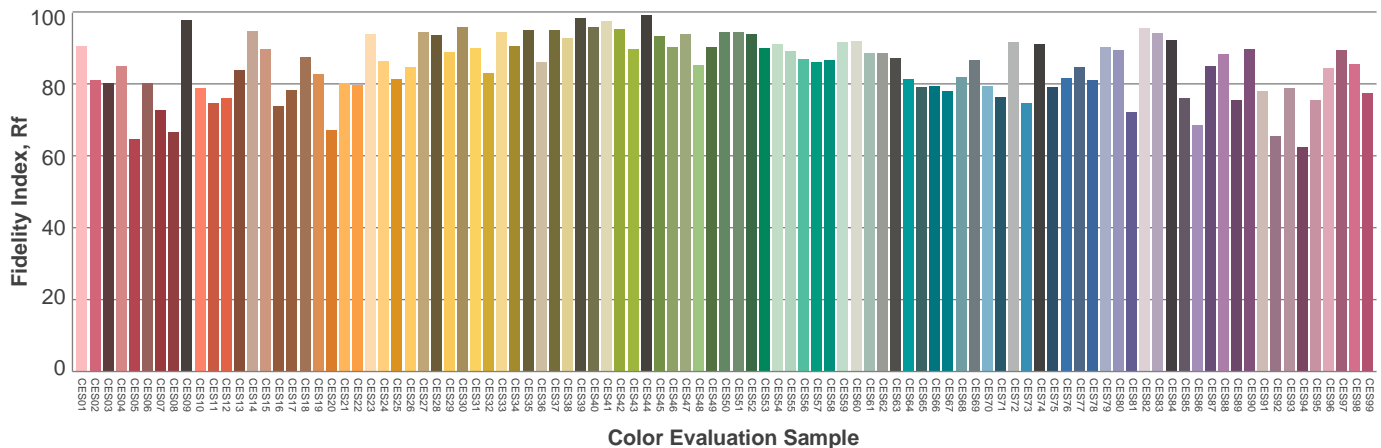
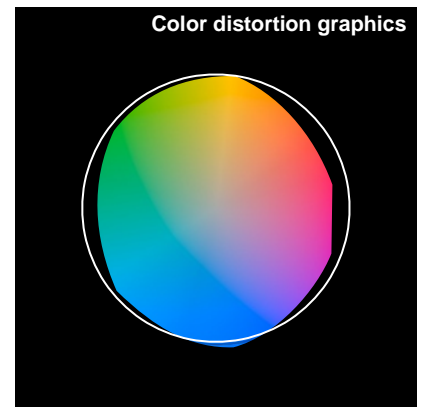
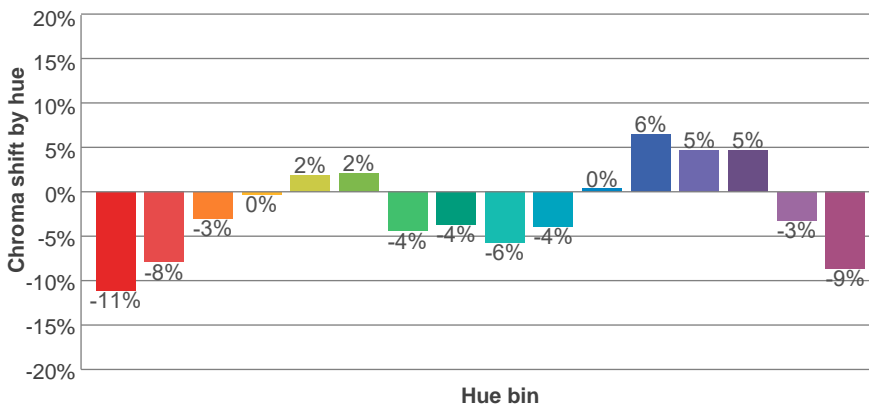
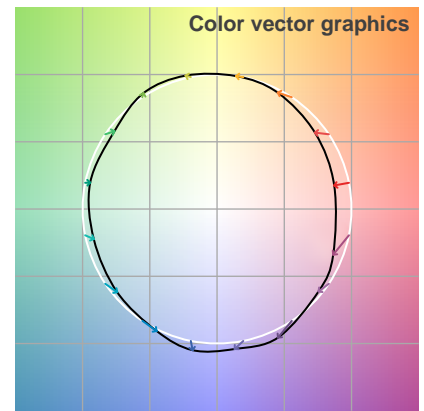
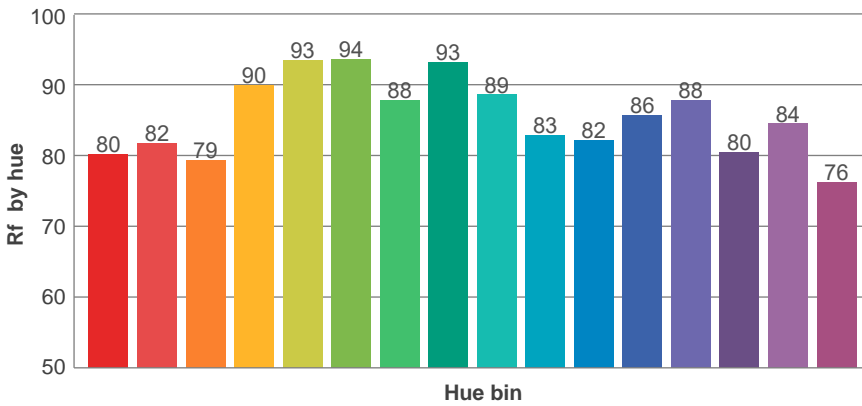
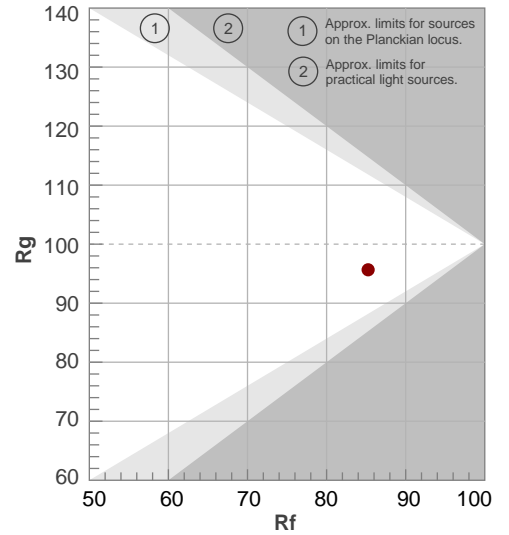

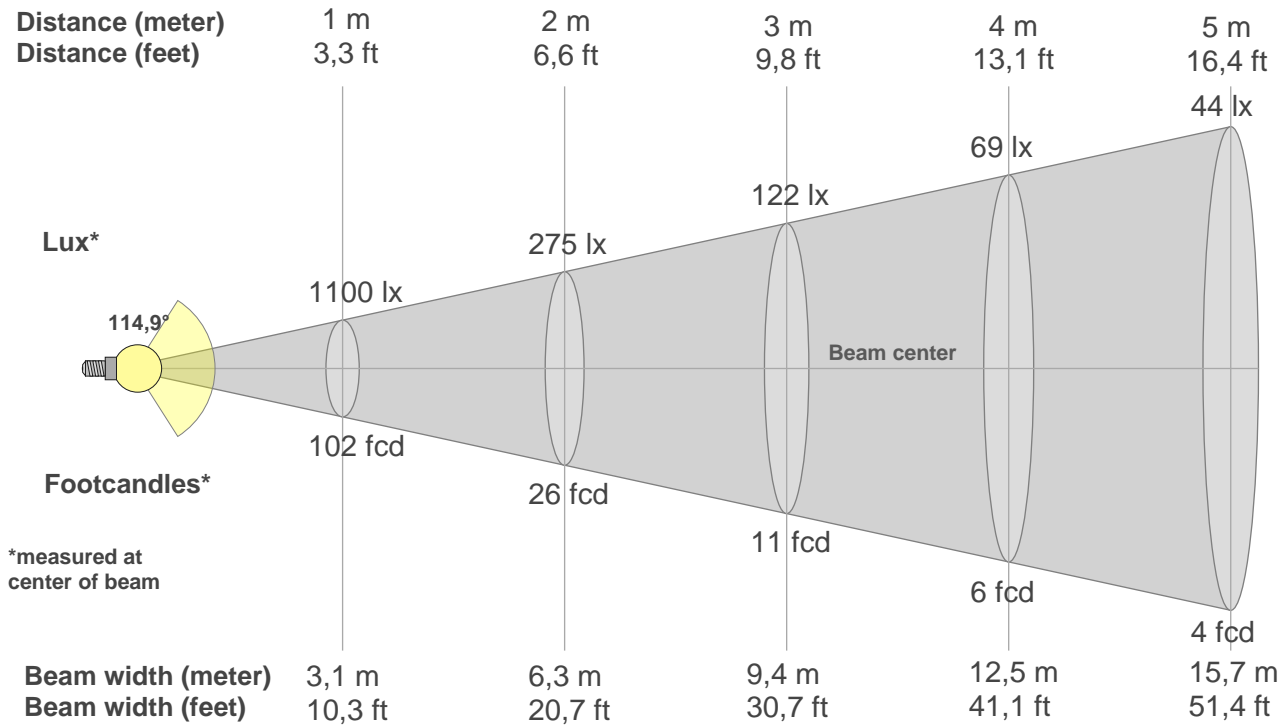

Beam intensities from 1-20m

1m	2m	3m	4m	5m	6m	7m	8m	9m	10m	11m	12m	13m	14m	15m	16m	17m	18m	19m	20m
3,3ft	6,6ft	9,8ft	13,1ft	16,4ft	19,7ft	23ft	26,2ft	29,5ft	32,8ft	36,1ft	39,4ft	42,7ft	45,9ft	49,2ft	52,5ft	55,8ft	59,1ft	62,3ft	65,6ft
1100lx	275lx	122lx	69lx	44lx	31lx	22lx	17lx	14lx	11lx	9lx	8lx	7lx	6lx	5lx	4lx	4lx	3lx	3lx	3lx
102,2fcd	25,5fcd	11,4fcd	6,4fcd	4,1fcd	2,8fcd	2,1fcd	1,6fcd	1,3fcd	1fcd	0,8fcd	0,7fcd	0,6fcd	0,5fcd	0,5fcd	0,4fcd	0,4fcd	0,3fcd	0,3fcd	0,3fcd

Intensities in 0° c-plane

0°	5°	10°	15°	20°	25°	30°	35°	40°	45°	50°	55°	60°	65°	70°	75°	80°	85°	90°	95°
1100	1096	1083	1062	1033	995	949	895	834	764	688	605	517	425	331	238	149	70	17	2
100%	100%	98%	97%	94%	90%	86%	81%	76%	69%	63%	55%	47%	39%	30%	22%	14%	6%	2%	0%

Intensities in 90° c-plane

0°	5°	10°	15°	20°	25°	30°	35°	40°	45°	50°	55°	60°	65°	70°	75°	80°	85°	90°	95°
1100	1095	1081	1057	1026	984	934	877	813	741	663	580	493	403	312	224	139	64	17	3
100%	100%	98%	96%	93%	89%	85%	80%	74%	67%	60%	53%	45%	37%	28%	20%	13%	6%	2%	0%

Intensities in 180° c-plane

0°	5°	10°	15°	20°	25°	30°	35°	40°	45°	50°	55°	60°	65°	70°	75°	80°	85°	90°	95°
1100	1096	1083	1062	1033	995	949	895	834	764	688	605	517	425	331	238	149	70	17	2
100%	100%	98%	97%	94%	90%	86%	81%	76%	69%	63%	55%	47%	39%	30%	22%	14%	6%	2%	0%

Intensities in 270° c-plane

0°	5°	10°	15°	20°	25°	30°	35°	40°	45°	50°	55°	60°	65°	70°	75°	80°	85°	90°	95°
1100	1095	1081	1057	1026	984	934	877	813	741	663	580	493	403	312	224	139	64	17	3
100%	100%	98%	96%	93%	89%	85%	80%	74%	67%	60%	53%	45%	37%	28%	20%	13%	6%	2%	0%

Beam angle 50%	Field angle 10%	Cutoff angle 2,5%	Intensity ratio in 120° cone	Intensity ratio in 90° cone
114,9°	164,2°	176,6°	77,2%	52,2%

iso-candela diagram

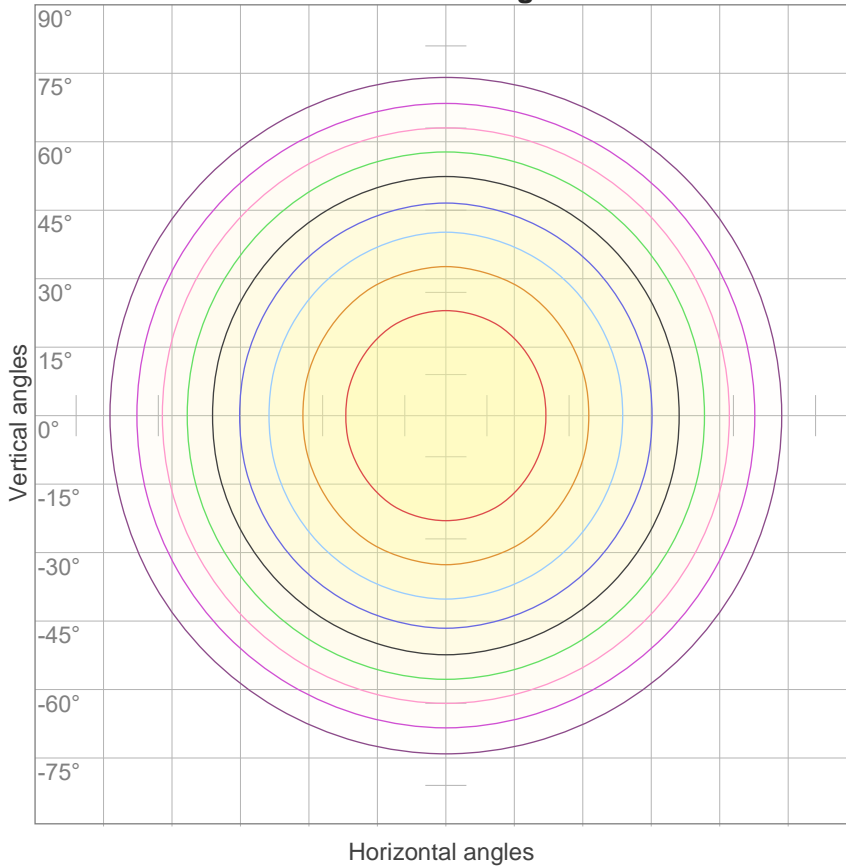

10%	110 cd
20%	220 cd
30%	330 cd
40%	440 cd
50%	550 cd
60%	660 cd
70%	770 cd
80%	880 cd
90%	990 cd

Conditions:

Number of c-planes: 12

Candela at center: 1100 cd

iso-lux diagram

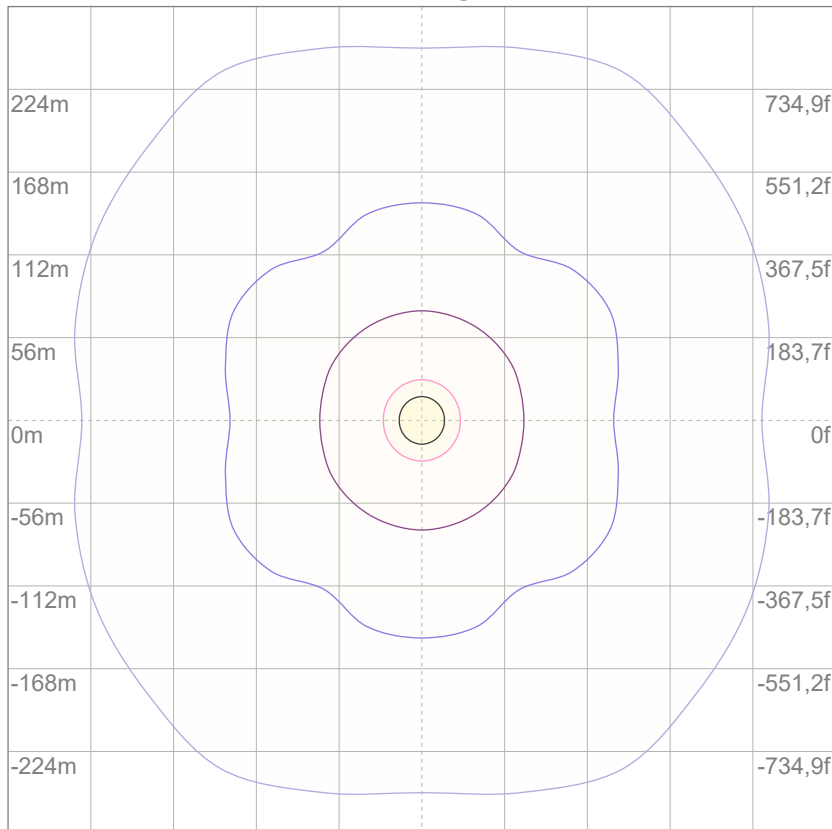

Mounting height: 10 meters (33 feet)

3%	0,330 lx
5%	0,550 lx
10%	1,10 lx
30%	3,30 lx
50%	5,50 lx

Conditions:

Number of c-planes: 12

Lux at center: 11,0 lx

Lux distribution on a surface when lamp is mounted at 10 meters from the surface.

Glare evaluation according to UGR

p Ceiling	70	70	50	50	30	70	70	50	50	30	
p Walls	50	30	50	30	30	50	30	50	30	30	
p Floor	20	20	20	20	20	20	20	20	20	20	
Room size X Y	Viewing direction at right angles to lamp axis					Viewing direction parallel to lamp axis					
2H	2H	17,0	18,2	17,2	18,5	18,8	16,7	17,9	16,9	18,3	18,5
	3H	18,5	19,8	18,9	20,1	20,3	18,1	19,4	18,6	19,7	19,9
	4H	19,2	20,4	19,6	20,7	21,0	18,8	20,0	19,2	20,3	20,6
	6H	19,8	20,9	20,1	21,2	21,6	19,3	20,4	19,6	20,7	21,1
	8H	20,0	21,0	20,3	21,3	21,8	19,5	20,5	19,8	20,8	21,2
12H	20,1	21,1	20,5	21,4	21,9	19,5	20,5	19,9	20,9	21,4	
4H	2H	17,6	18,8	18,0	19,1	19,3	17,3	18,6	17,8	18,8	19,1
	3H	19,4	20,4	19,8	20,8	21,2	19,1	20,1	19,5	20,5	20,9
	4H	20,1	21,1	20,6	21,5	22,1	19,8	20,7	20,2	21,1	21,7
	6H	20,8	21,7	21,3	22,1	22,4	20,4	21,3	20,9	21,6	22,0
	8H	21,0	21,8	21,5	22,2	22,6	20,6	21,4	21,1	21,8	22,1
12H	21,2	21,9	21,7	22,3	22,8	20,7	21,4	21,2	21,8	22,3	
8H	4H	20,4	21,2	20,9	21,6	22,0	20,1	20,9	20,6	21,3	21,7
	6H	21,2	21,9	21,7	22,3	22,9	20,8	21,5	21,4	21,9	22,5
	8H	21,6	22,1	22,1	22,6	23,3	21,1	21,7	21,7	22,2	22,9
	12H	21,8	22,3	22,4	22,8	23,4	21,4	21,8	21,9	22,3	23,0
12H	4H	20,4	21,1	20,9	21,6	22,0	20,1	20,8	20,6	21,2	21,7
	6H	21,3	21,9	21,8	22,4	23,0	20,9	21,5	21,5	22,0	22,7
	8H	21,7	22,1	22,3	22,6	23,3	21,3	21,7	21,8	22,2	22,9
Variation of the observer position for the luminaire distance S											
S = 1.0H	0,1 / -0,1					0,1 / -0,1					
S = 1.5H	0,1 / -0,2					0,1 / -0,2					
S = 2.0H	0,4 / -0,4					0,4 / -0,5					
CIE 117-1995. Corrected glare indices referring to 3272 lm total luminous flux											

Coefficients of Utilization

Ceiling reflectance	80				70				50			30			10			0
	70	50	30	10	70	50	30	10	50	30	10	50	30	10	50	30	10	0
Wall reflectance	70	50	30	10	70	50	30	10	50	30	10	50	30	10	50	30	10	0
Floor reflectance	20	20	20	20	20	20	20	20	20	20	20	20	20	20	20	20	20	0
RCR	(RCR: Room Cavity Ratio)																	
	Room Values are expressed as percentage of Lumens delivered to the task surface																	
0	119	119	119	119	116	116	116	116	111	111	111	106	106	106	102	102	102	99
1	108	103	99	95	105	101	97	93	97	93	90	93	90	87	89	87	85	83
2	98	90	83	77	96	88	81	76	84	79	74	81	76	72	78	74	71	68
3	89	79	70	64	87	77	69	63	74	67	62	71	65	61	68	64	60	57
4	82	70	61	54	79	68	60	53	66	58	53	63	57	52	61	55	51	49
5	75	62	53	46	73	61	52	46	59	51	45	57	50	45	55	49	44	42
6	69	56	47	40	67	55	46	40	53	45	40	51	44	39	50	43	39	37
7	64	51	42	35	62	50	41	35	48	40	35	47	40	35	45	39	34	32
8	60	46	37	32	58	45	37	31	44	36	31	43	36	31	41	35	31	29
9	56	42	34	28	54	42	34	28	40	33	28	39	33	28	38	32	28	26
10	52	39	31	26	51	38	31	26	37	30	25	36	30	25	35	29	25	23

LAMPS (number of lamps)

Luminaire budgetary diagram

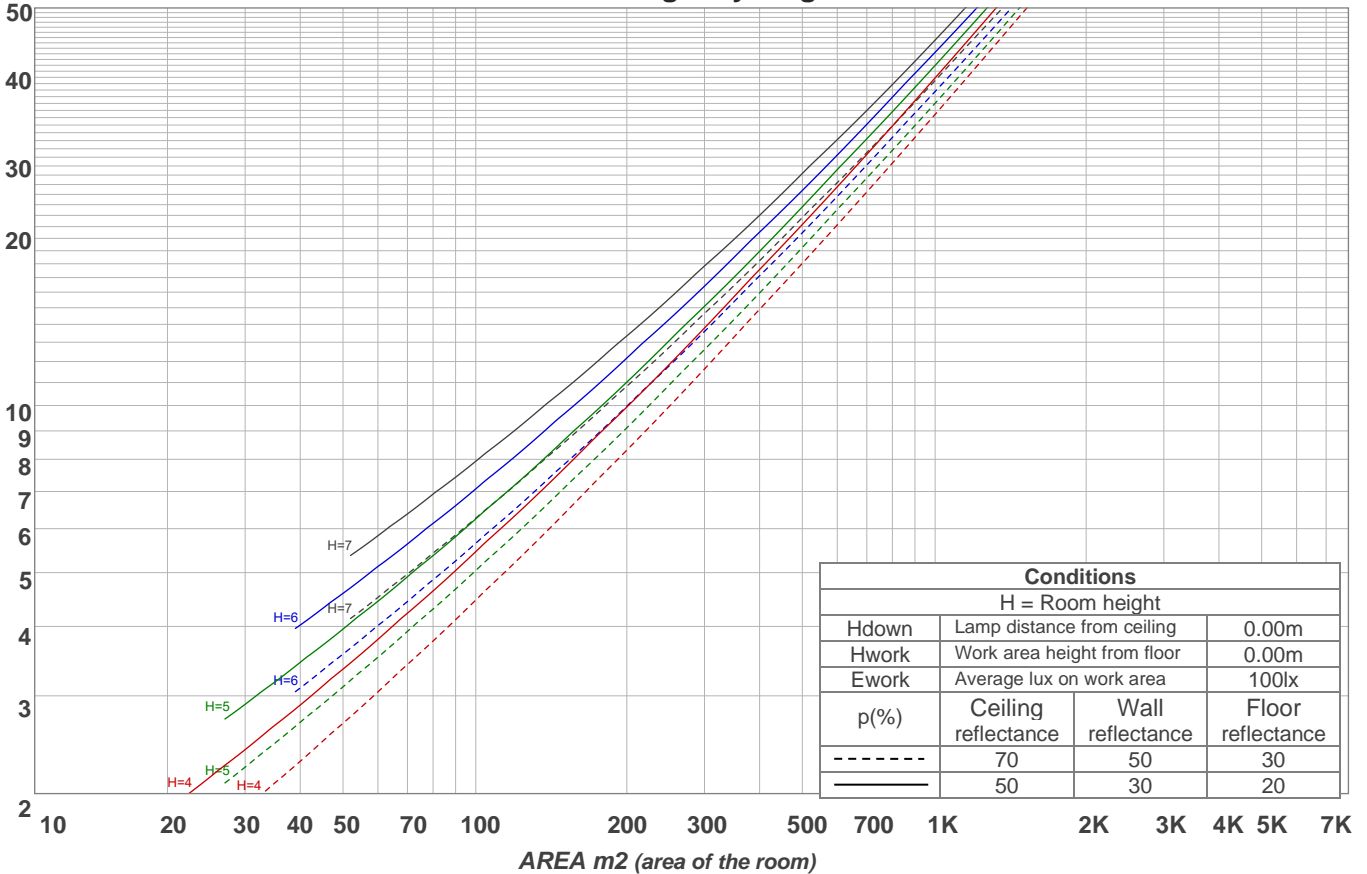

Zonal Lumen Summary

0°-10°	10°-20°	20°-30°	30°-40°	40°-50°	50°-60°	60°-70°	70°-80°	80°-90°
{LUM0-10}	299 lm	456 lm	555 lm	581 lm	530 lm	409 lm	242 lm	76,5 lm
90°-100°	100°-110°	110°-120°	120°-130°	130°-140°	140°-150°	150°-160°	160°-170°	170°-180°
3,90 lm	2,10 lm	2,34 lm	2,46 lm	2,51 lm	2,25 lm	1,79 lm	1,17 lm	0,401 lm

LCS table

BUG rating:	B1 U2 G1	
Forward light	Lumens	Lumens %
Low(0-30):	429,6	13,1%
Medium(30-60):	831,8	25,4%
High(60-80):	326,3	10%
Very high(80-90):	38,7	1,2%
Back light		
Low(0-30):	429,6	13,1%
Medium(30-60):	831,8	25,4%
High(60-80):	326,3	10%
Very high(80-90):	38,7	1,2%
Uplight		
Low(90-100):	4,3	0,1%
High(100-180):	15	0,5%

LCS graph

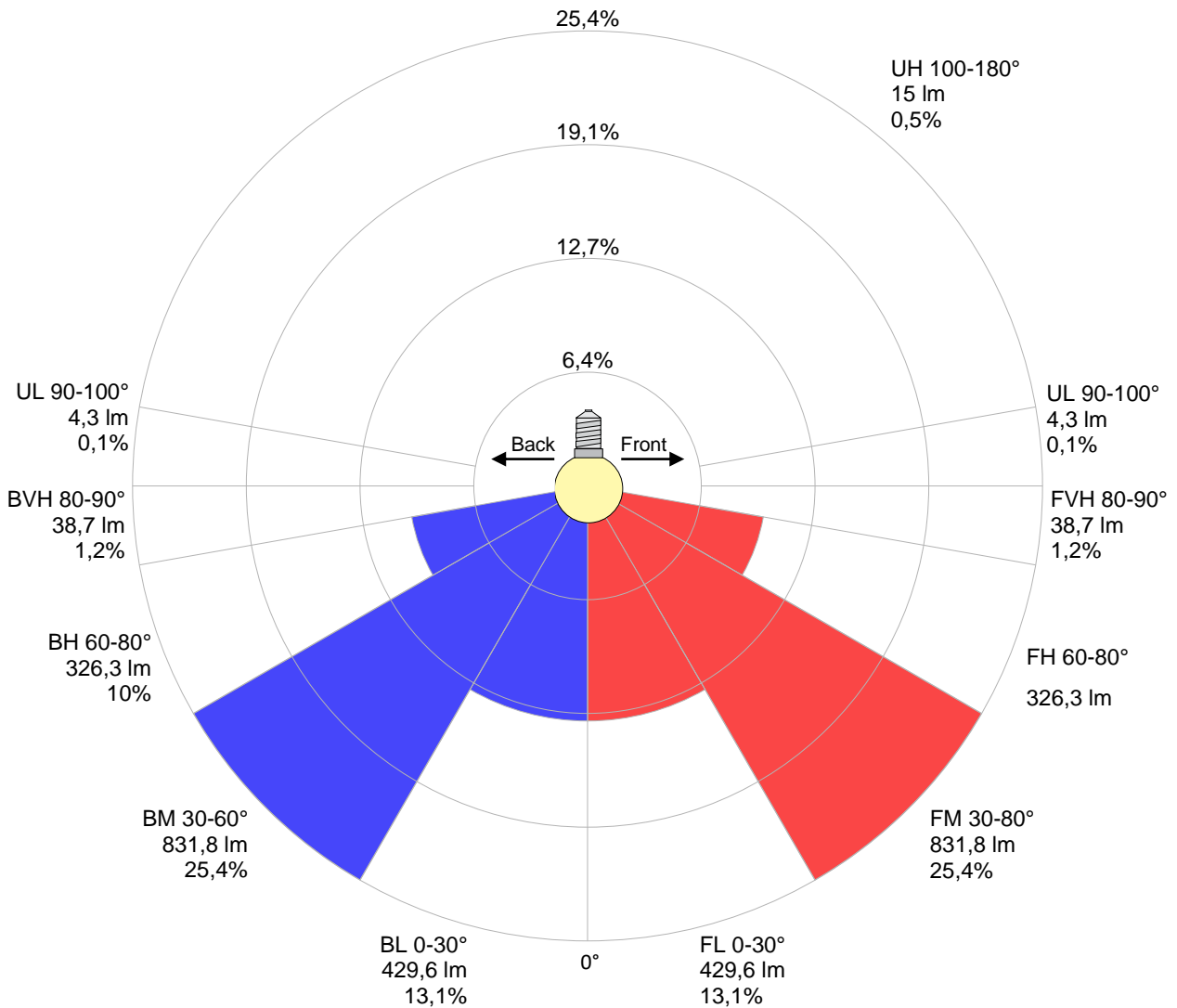

Warmup curve

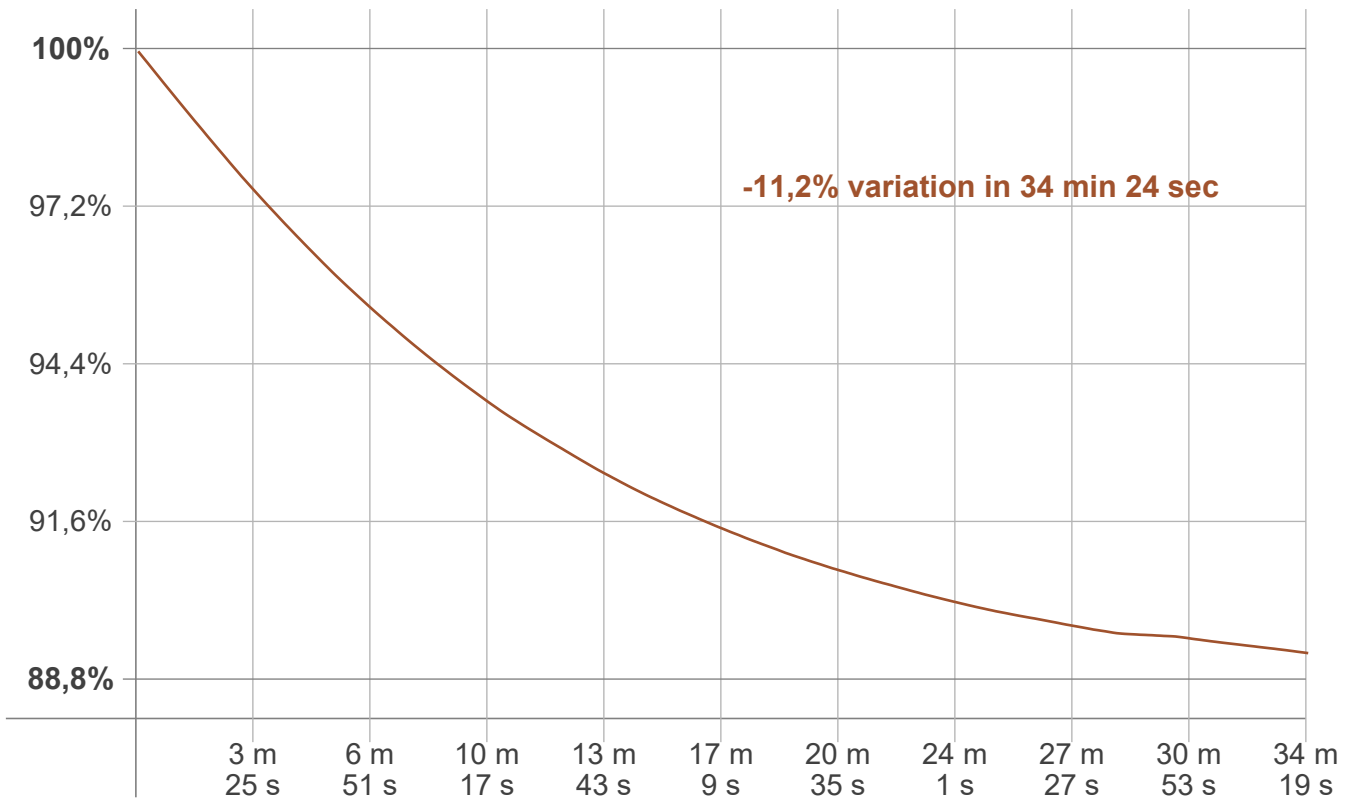

Warmup result

Warmup time:	Lamp stabilized in 34 min 24 sec
Warmup variation	-11,2%

Warmup conditions

Stable period:	15 min
Stable change max:	2,0%
Minimum time:	15 min

Color temperature change

CCT start	CCT change	CCT end
3002 K	-2 K	3000 K

Output change

Output start	Output change	Output end
3680 lm	-408 lm	3272 lm

Flicker curve (complete sampled flicker signal)



Flicker frame (frame of one flicker period)

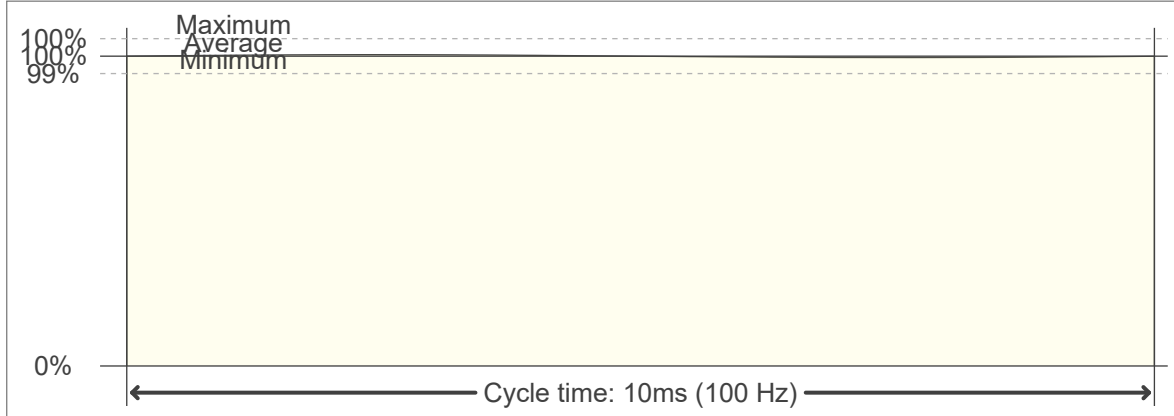

Flicker FFT (frequency scope of flicker curve)



Flicker results:

Flicker frequency:		100 Hz	
Flicker index:	0	JA8/10 40Hz	0,04 %
Flicker percentage:	0,52 %	JA8/10 90Hz	0,05 %
SVM: (Visual flicker)	0,02	JA8/10 200Hz	0,51 %
PstLM	0,04	JA8/10 400Hz	0,51 %
Mp	0,03	JA8/10 1000Hz	0,52 %

Flicker conditions:

Sample rate:	20000 samples/second
--------------	----------------------