

Light efficiency:



Light quality:



Color temperature:



Output: 167 lm
Peak: 68,5 cd
Power: 2,8 W
PF: 0,44

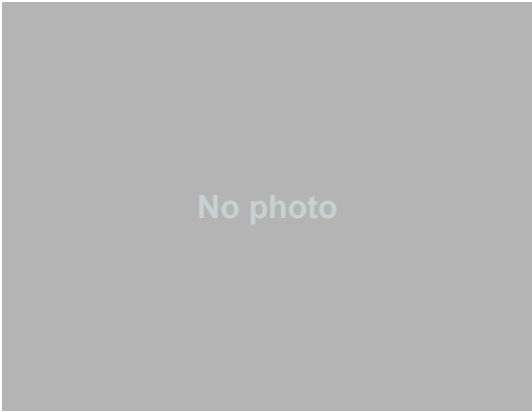

Tracking number: [VT240905-006263](#)

Product name:
805524
Item number:
805524
Date and time:
5-9-2024 12:25:18
Description:

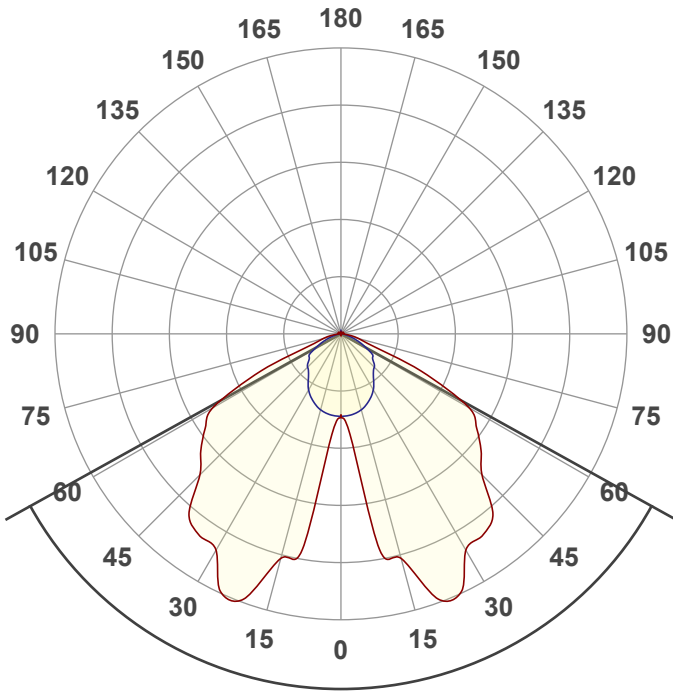

Beam angle **122°**



CIE 1931
x: 0,314
y: 0,324

Spectra

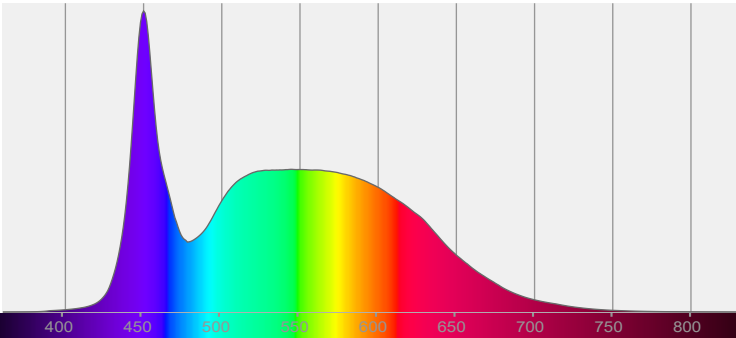

Power

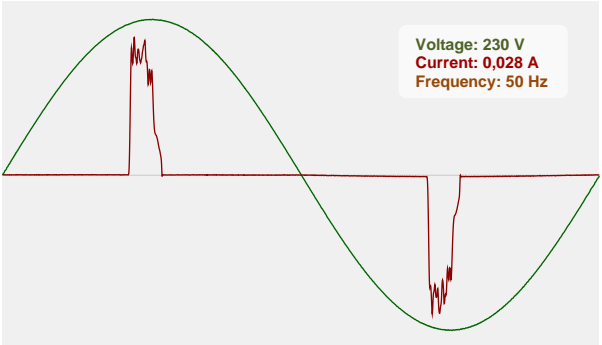

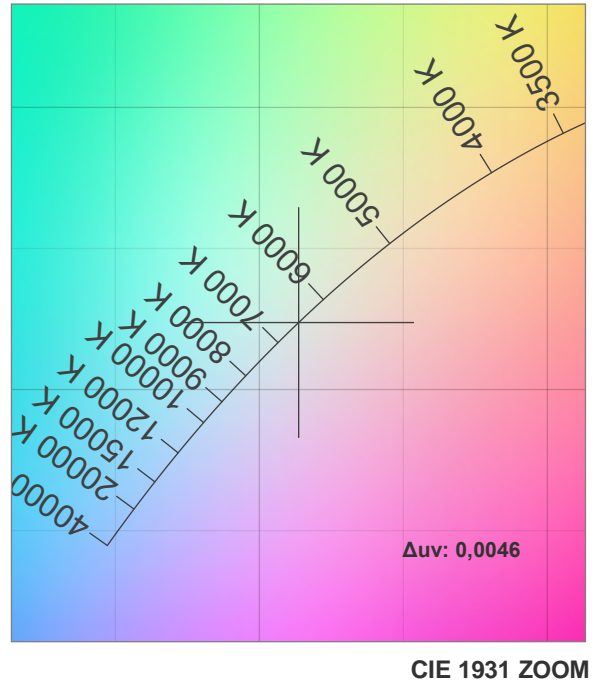
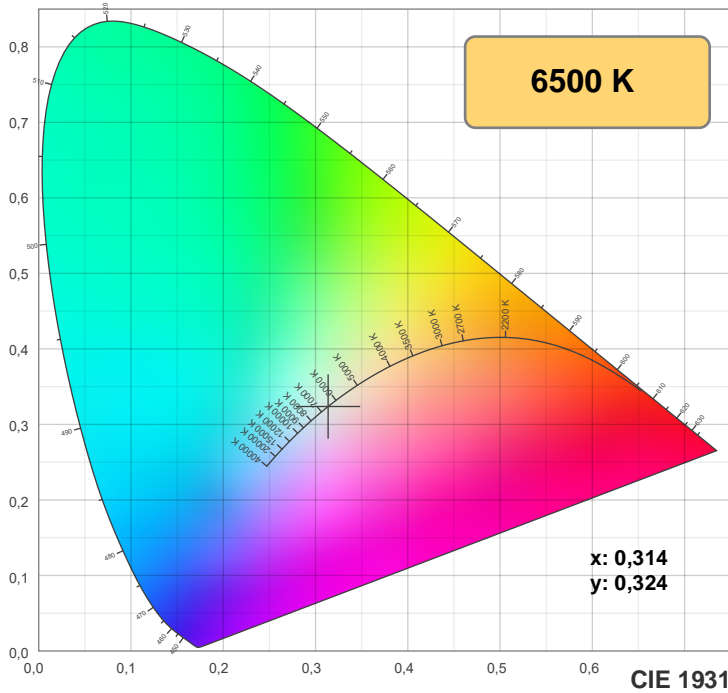

TM-30: 84,5

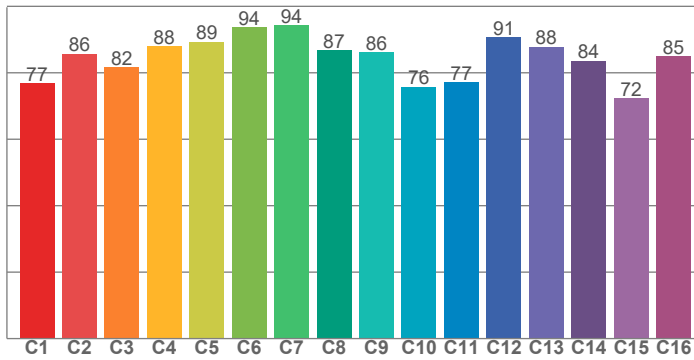

CRI: 83,3 (R1-R8)

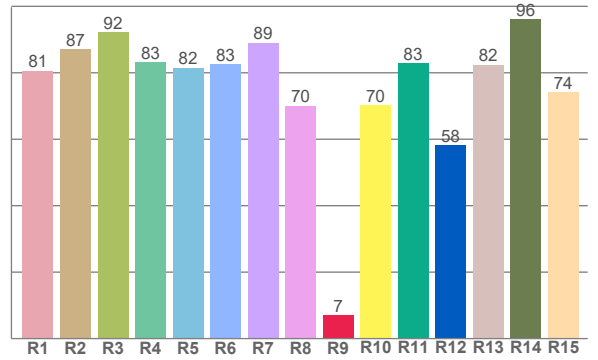

CQS: 82,9

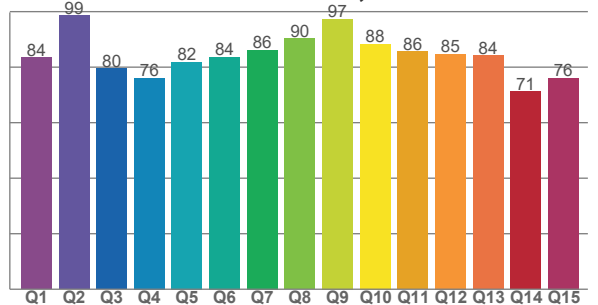

CRI R values, only R1-R8 are used to calculate final CRI value

R1	R2	R3	R4	R5	R6	R7	R8	R9	R10	R11	R12	R13	R14	R15
80,6	87,1	92,2	83,3	81,5	82,7	89,0	70,1	7,1	70,2	82,9	58,2	82,4	96,1	74,2

TM30 C values, 16 binned values out of total of 99 C values

C1	C2	C3	C4	C5	C6	C7	C8	C9	C10	C11	C12	C13	C14	C15	C16
76,8	85,7	81,6	88,0	89,3	93,8	94,2	86,8	86,2	75,8	77,1	90,7	87,8	83,6	72,4	84,9

CQS Q values

Q1	Q2	Q3	Q4	Q5	Q6	Q7	Q8	Q9	Q10	Q11	Q12	Q13	Q14	Q15
83,5	98,6	79,5	76,1	81,8	83,7	86,2	90,3	97,3	88,4	85,7	84,8	84,1	71,1	76,0

Color parameters

Color temperature	Color rendering Index	Red component	Color fidelity	Color gamut	Color quality scale	Color coordinate cie 1931	Color coordinate cie 1931	Color coordinate	Color coordinate	Color deviation from black body
CCT	CRI	CRI R9	TM30 Rf	TM30 Rg	CQS	x	y	u	v	Δuv
6500 K	83,3	7,1	84,5	94,8	82,9	0,314	0,324	0,200	0,310	0,0046

Rf 84,5
Fidelity index Rf

Rg 94,8
Gamut index Rg

Hue Bin	R _f	Shifts (%)	
		Chroma	Hue
1	77	-12%	-2%
2	86	-8%	5%
3	82	-5%	9%
4	88	0%	7%
5	89	-1%	3%
6	94	0%	-1%
7	94	-2%	-3%
8	87	-8%	-1%
9	86	-9%	8%
10	76	-5%	14%
11	77	2%	14%
12	91	4%	4%
13	88	8%	-5%
14	84	4%	-9%
15	72	5%	-24%
16	85	-6%	-7%

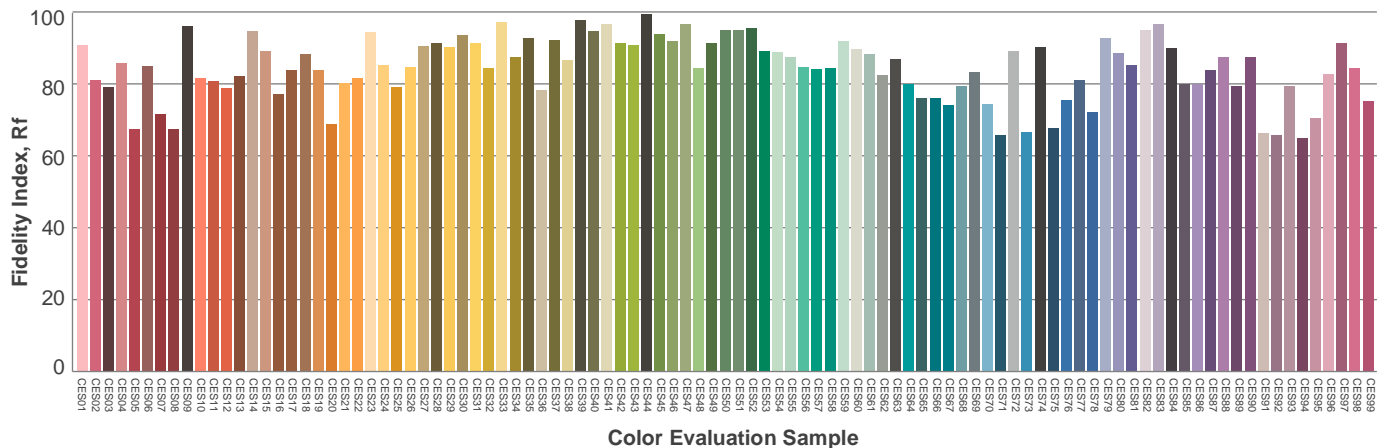
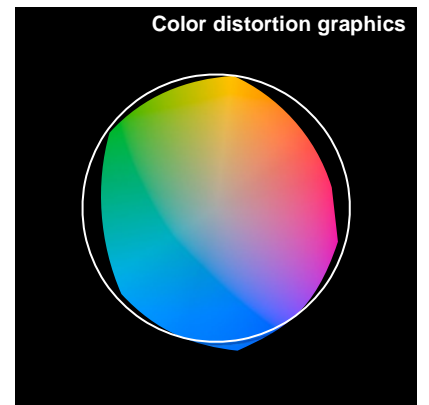
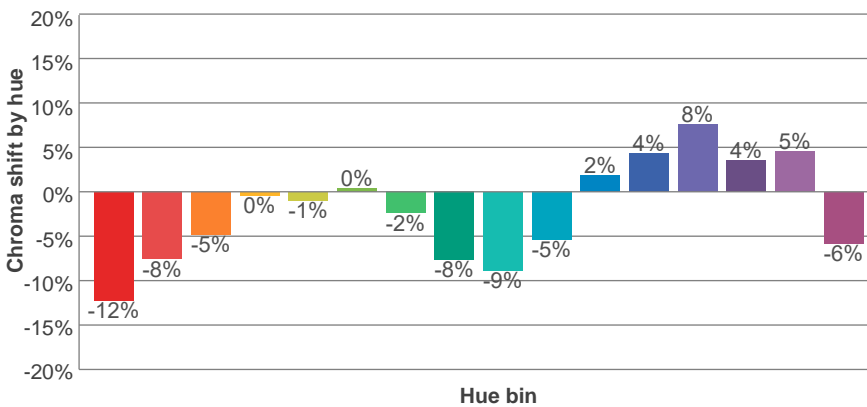
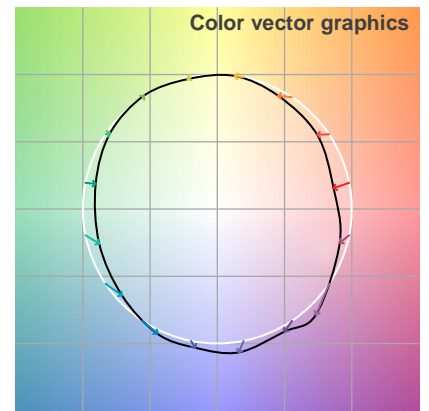
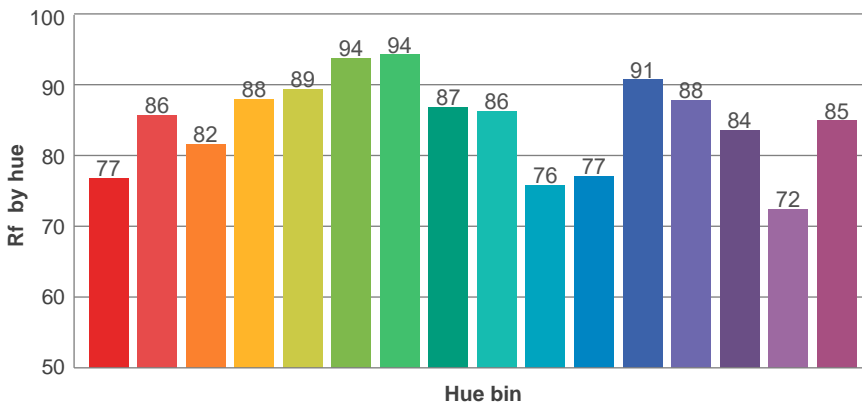
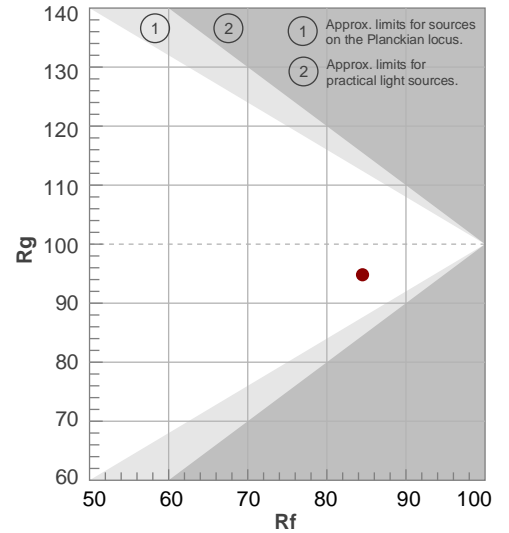

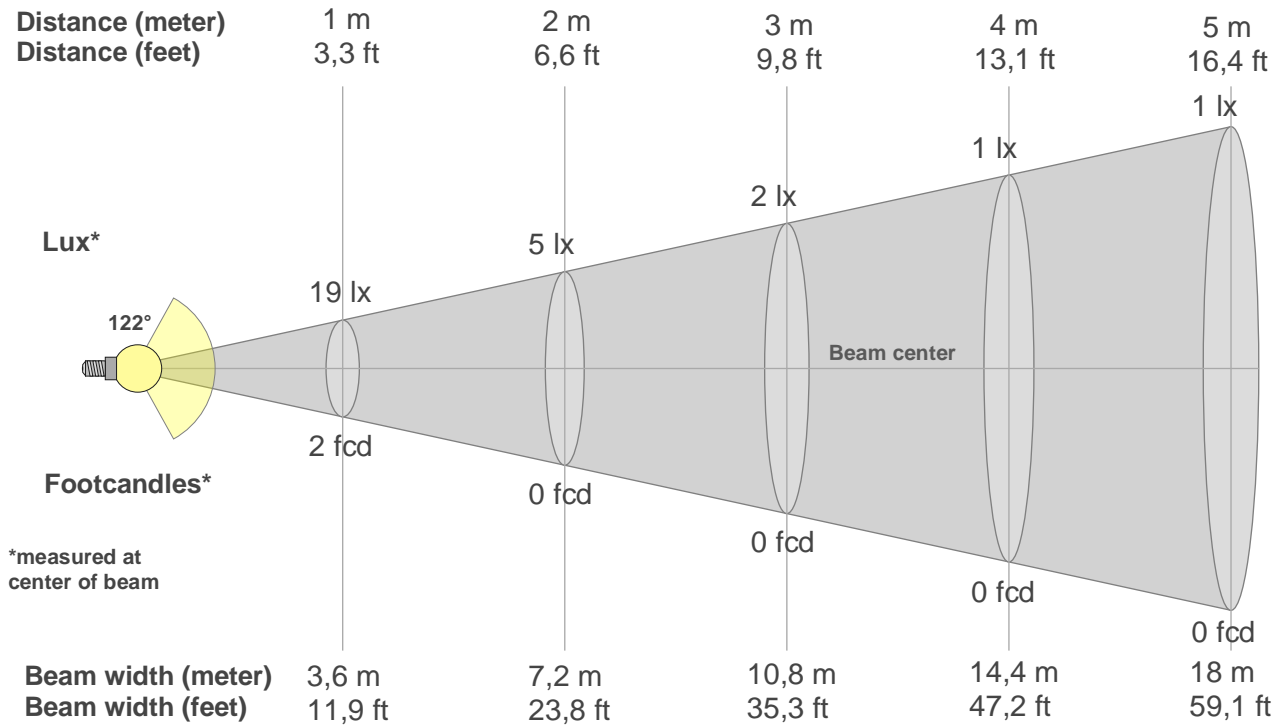

Beam intensities from 1-20m

1m	2m	3m	4m	5m	6m	7m	8m	9m	10m	11m	12m	13m	14m	15m	16m	17m	18m	19m	20m
3,3ft	6,6ft	9,8ft	13,1ft	16,4ft	19,7ft	23ft	26,2ft	29,5ft	32,8ft	36,1ft	39,4ft	42,7ft	45,9ft	49,2ft	52,5ft	55,8ft	59,1ft	62,3ft	65,6ft
19lx	5lx	2lx	1lx	1lx	1lx	0lx	0lx	0lx	0lx	0lx	0lx	0lx	0lx	0lx	0lx	0lx	0lx	0lx	0lx
1,8fcd	0,5fcd	0,2fcd	0,1fcd	0,1fcd	0,1fcd	0fcd	0fcd	0fcd	0fcd	0fcd	0fcd	0fcd	0fcd	0fcd	0fcd	0fcd	0fcd	0fcd	0fcd

Intensities in 0° c-plane

0°	5°	10°	15°	20°	25°	30°	35°	40°	45°	50°	55°	60°	65°	70°	75°	80°	85°	90°	95°
19,4	23,7	50,8	54,8	66,2	66,9	58,9	58,0	55,6	47,0	43,1	39,1	34,7	21,1	7,2	4,4	2,5	0,9	0,4	0,3
100%	122%	262%	283%	342%	345%	304%	299%	287%	243%	222%	202%	179%	109%	37%	23%	13%	5%	2%	2%

Intensities in 90° c-plane

0°	5°	10°	15°	20°	25°	30°	35°	40°	45°	50°	55°	60°	65°	70°	75°	80°	85°	90°	95°
19,4	19,3	19,0	18,5	17,6	16,5	15,2	13,4	12,0	11,1	10,0	9,1	7,3	5,1	3,3	1,9	0,9	0,4	0,2	0,2
100%	100%	98%	95%	91%	85%	78%	69%	62%	57%	51%	47%	38%	26%	17%	10%	5%	2%	1%	1%

Intensities in 180° c-plane

0°	5°	10°	15°	20°	25°	30°	35°	40°	45°	50°	55°	60°	65°	70°	75°	80°	85°	90°	95°
19,4	23,7	50,8	54,8	66,2	66,9	58,9	58,0	55,6	47,0	43,1	39,1	34,7	21,1	7,2	4,4	2,5	0,9	0,4	0,3
100%	122%	262%	283%	342%	345%	304%	299%	287%	243%	222%	202%	179%	109%	37%	23%	13%	5%	2%	2%

Intensities in 270° c-plane

0°	5°	10°	15°	20°	25°	30°	35°	40°	45°	50°	55°	60°	65°	70°	75°	80°	85°	90°	95°
19,4	19,3	19,0	18,5	17,6	16,5	15,2	13,4	12,0	11,1	10,0	9,1	7,3	5,1	3,3	1,9	0,9	0,4	0,2	0,2
100%	100%	98%	95%	91%	85%	78%	69%	62%	57%	51%	47%	38%	26%	17%	10%	5%	2%	1%	1%

Beam angle 50%	Field angle 10%	Cutoff angle 2,5%	Intensity ratio in 120° cone	Intensity ratio in 90° cone
122°	151,9°	169,6°	79,0%	50,7%

iso-candela diagram

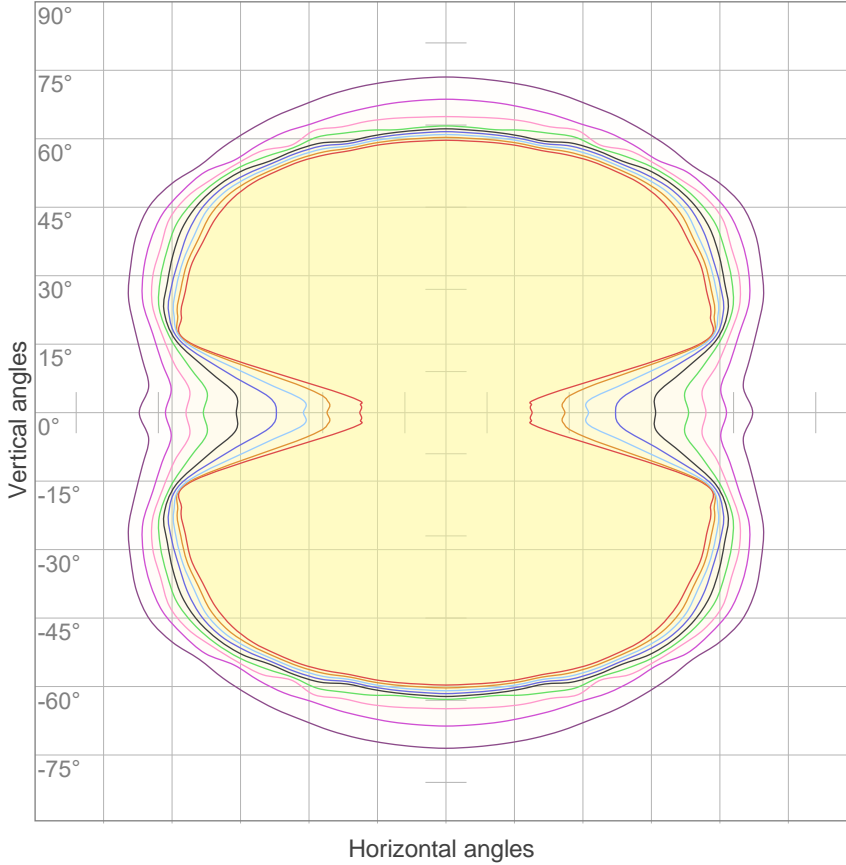

- 10% 2 cd
- 20% 4 cd
- 30% 6 cd
- 40% 8 cd
- 50% 10 cd
- 60% 12 cd
- 70% 14 cd
- 80% 16 cd
- 90% 17 cd

Conditions:

Number of c-planes: 72

Candela at center: 19 cd

iso-lux diagram

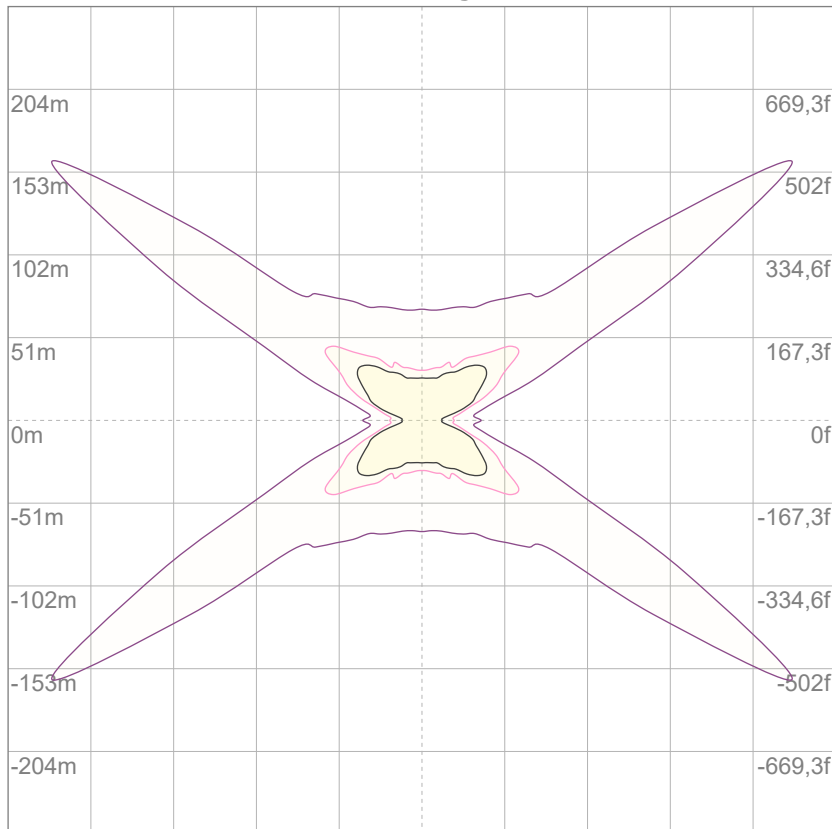

- 3% 5,81m lx
- 5% 9,69m lx
- 10% 19,4m lx
- 30% 58,1m lx
- 50% 96,9m lx

Conditions:

Number of c-planes: 72

Lux at center: 0,194 lx

Lux distribution on a surface when lamp is mounted at 10 meters from the surface.

Glare evaluation according to UGR

p Ceiling	70	70	50	50	30	70	70	50	50	30	
p Walls	50	30	50	30	30	50	30	50	30	30	
p Floor	20	20	20	20	20	20	20	20	20	20	
Room size X Y	Viewing direction at right angles to lamp axis					Viewing direction parallel to lamp axis					
2H	2H	13,1	14,4	13,4	14,7	15,0	11,6	12,8	11,8	13,2	13,4
	3H	13,5	14,8	13,9	15,1	15,3	11,9	13,2	12,3	13,5	13,7
	4H	13,5	14,7	13,9	15,0	15,3	11,9	13,1	12,3	13,4	13,7
	6H	13,5	14,6	13,9	14,9	15,3	11,9	12,9	12,2	13,2	13,6
	8H	13,5	14,5	13,9	14,8	15,3	11,8	12,9	12,2	13,2	13,6
	12H	13,4	14,4	13,8	14,8	15,3	11,8	12,8	12,2	13,1	13,6
4H	2H	13,8	15,0	14,2	15,3	15,6	12,7	13,9	13,1	14,2	14,5
	3H	14,5	15,5	14,9	15,9	16,3	13,6	14,6	14,0	14,9	15,4
	4H	14,5	15,4	14,9	15,8	16,4	13,6	14,5	14,1	15,0	15,5
	6H	14,4	15,3	14,9	15,7	16,1	13,6	14,5	14,1	14,8	15,2
	8H	14,4	15,2	14,9	15,6	16,0	13,6	14,3	14,1	14,7	15,1
	12H	14,4	15,0	14,9	15,5	16,0	13,5	14,2	14,0	14,6	15,1
8H	4H	14,7	15,5	15,2	15,8	16,3	13,9	14,7	14,5	15,1	15,5
	6H	14,7	15,3	15,2	15,8	16,3	14,1	14,7	14,6	15,1	15,7
	8H	14,7	15,2	15,2	15,8	16,4	14,1	14,6	14,6	15,1	15,8
	12H	14,7	15,1	15,3	15,6	16,3	14,1	14,5	14,7	15,0	15,6
12H	4H	14,7	15,3	15,2	15,8	16,3	13,9	14,6	14,4	15,0	15,5
	6H	14,7	15,2	15,3	15,8	16,4	14,1	14,6	14,6	15,1	15,8
	8H	14,7	15,1	15,3	15,7	16,3	14,1	14,5	14,7	15,1	15,7
Variation of the observer position for the luminaire distance S											
S = 1.0H	0,3 / -0,4					0,4 / -0,5					
S = 1.5H	0,3 / -0,4					1,3 / -1,6					
S = 2.0H	1,3 / -2,1					1,8 / -2,6					
CIE 117-1995. Corrected glare indices referring to 167 lm total luminous flux											

Coefficients of Utilization

Ceiling reflectance	80				70				50			30			10			0	
	70	50	30	10	70	50	30	10	50	30	10	50	30	10	50	30	10	0	
Wall reflectance																			
Floor reflectance	20	20	20	20	20	20	20	20	20	20	20	20	20	20	20	20	20	20	0
RCR	(RCR: Room Cavity Ratio) Room Values are expressed as percentage of Lumens delivered to the task surface																		
0	119	119	119	119	116	116	116	116	110	110	110	105	105	105	101	101	101	99	
1	109	104	100	96	106	102	98	94	97	94	91	93	90	88	89	87	85	83	
2	99	90	83	78	96	88	82	77	84	79	75	81	77	73	78	74	71	69	
3	89	79	70	64	87	77	69	63	74	67	62	71	65	61	68	63	59	57	
4	81	69	60	53	79	68	59	53	65	58	52	62	56	51	60	55	50	48	
5	74	61	52	45	72	60	51	45	58	50	44	56	49	44	54	48	43	41	
6	68	55	45	39	66	54	45	39	52	44	38	50	43	38	48	42	37	35	
7	63	49	40	34	61	48	40	34	47	39	33	45	38	33	43	37	33	30	
8	58	44	36	30	57	44	35	30	42	35	29	41	34	29	40	33	29	27	
9	54	40	32	26	53	40	32	26	39	31	26	37	31	26	36	30	25	24	
10	51	37	29	23	49	36	29	23	35	28	23	34	28	23	33	27	23	21	

LAMPS (number of lamps)

Luminaire budgetary diagram

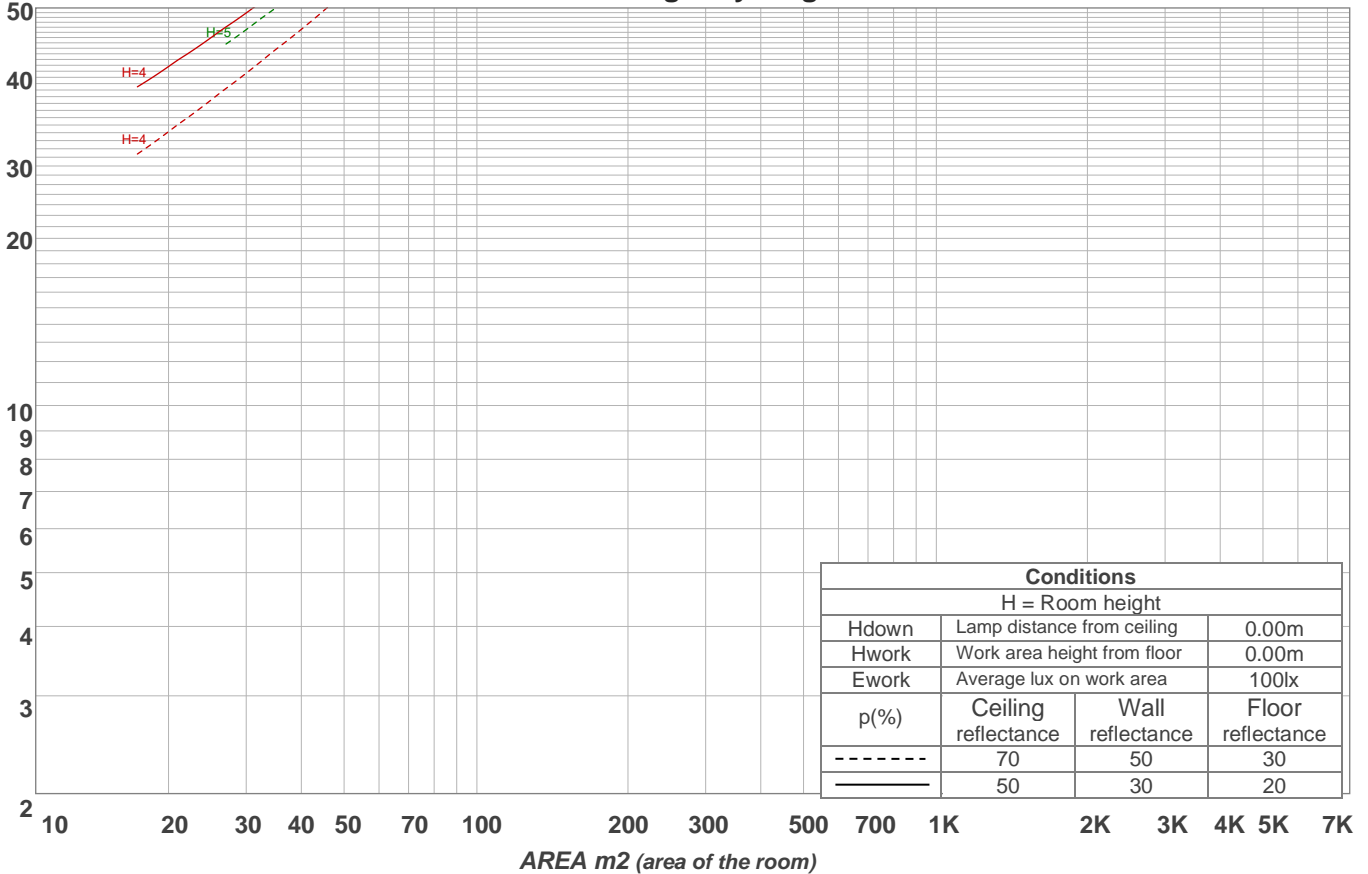

Zonal Lumen Summary

0°-10°	10°-20°	20°-30°	30°-40°	40°-50°	50°-60°	60°-70°	70°-80°	80°-90°
{LUM0-10}	11,9 lm	23,6 lm	30,4 lm	32,5 lm	30,9 lm	22,4 lm	8,46 lm	1,85 lm
90°-100°	100°-110°	110°-120°	120°-130°	130°-140°	140°-150°	150°-160°	160°-170°	170°-180°
0,506 lm	0,656 lm	0,538 lm	0,378 lm	0,190 lm	0,079 lm	0,036 lm	0,020 lm	0,007 lm

LCS table

BUG rating:	B0 U1 G0	
Forward light	Lumens	Lumens %
Low(0-30):	18,9	11,3%
Medium(30-60):	46,6	27,9%
High(60-80):	15,5	9,3%
Very high(80-90):	0,9	0,6%
Back light		
Low(0-30):	18,9	11,3%
Medium(30-60):	46,6	27,9%
High(60-80):	15,5	9,3%
Very high(80-90):	0,9	0,6%
Uplight		
Low(90-100):	0,5	0,3%
High(100-180):	1,9	1,1%

LCS graph

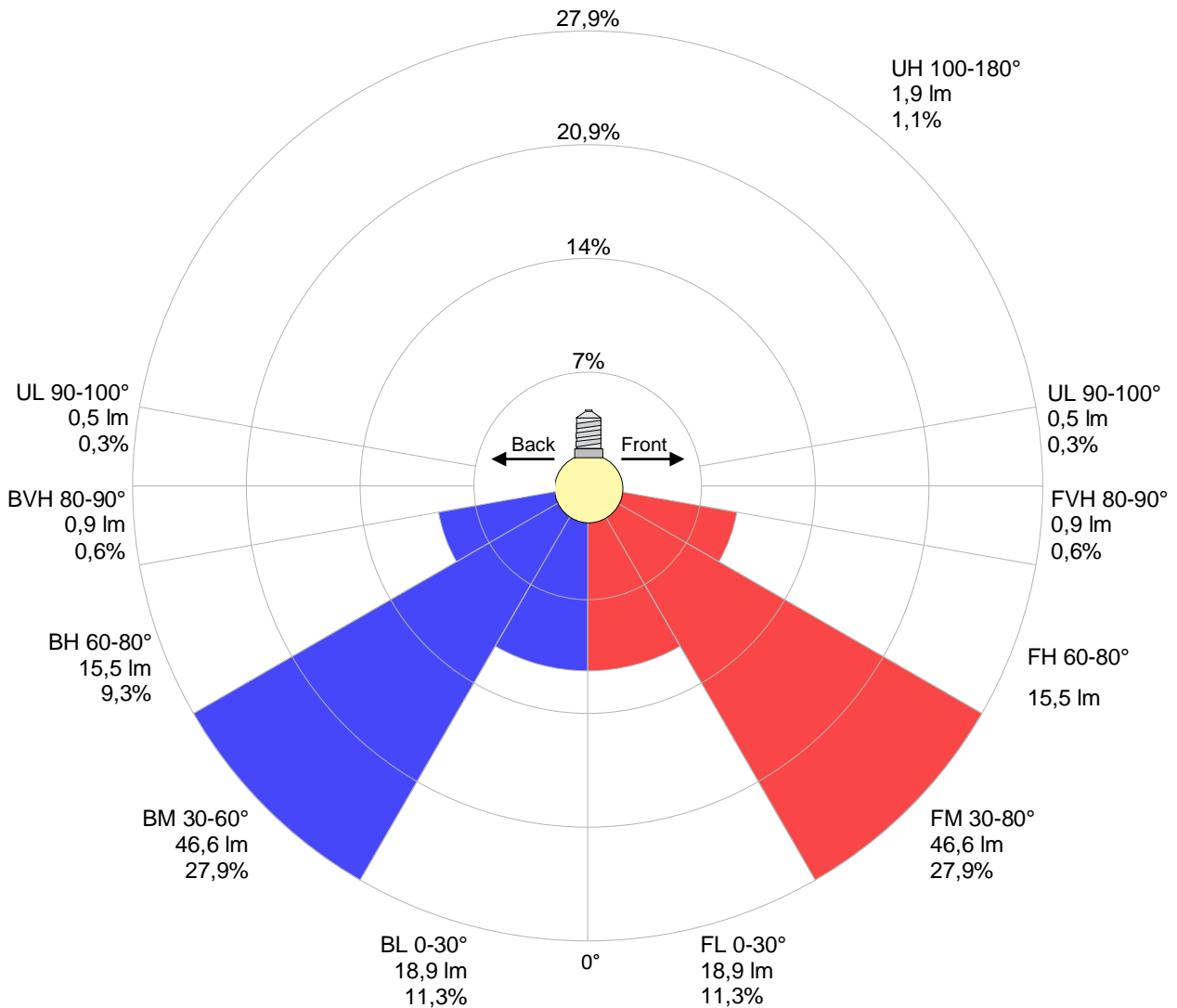

Warmup curve

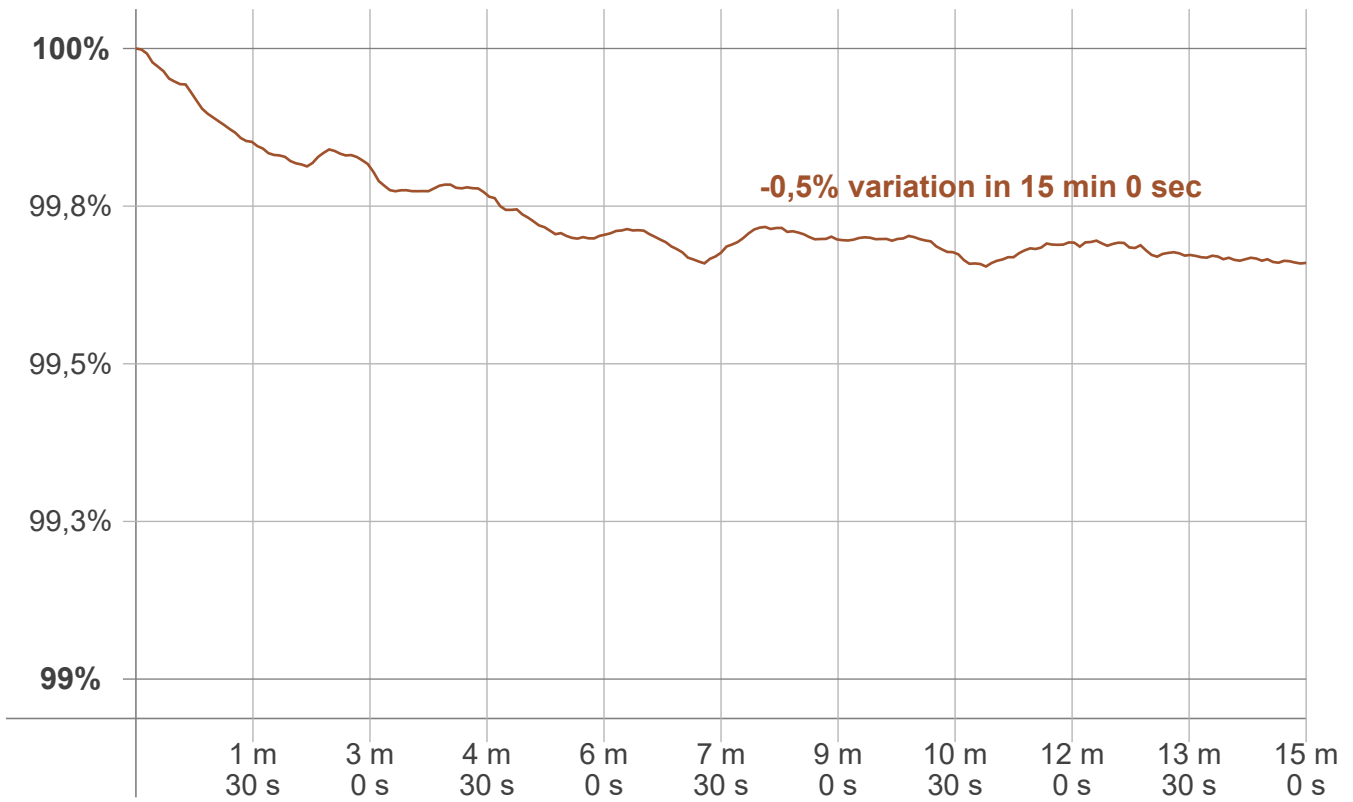

Warmup result

Warmup time:	Lamp stabilized in 15 min 0 sec
Warmup variation	-0,5%

Warmup conditions

Stable period:	15 min
Stable change max:	2,0%
Minimum time:	15 min

Color temperature change

CCT start	CCT change	CCT end
6597 K	-97 K	6500 K

Output change

Output start	Output change	Output end
167 lm	-1 lm	167 lm

Flicker curve (complete sampled flicker signal)



Flicker frame (frame of one flicker period)

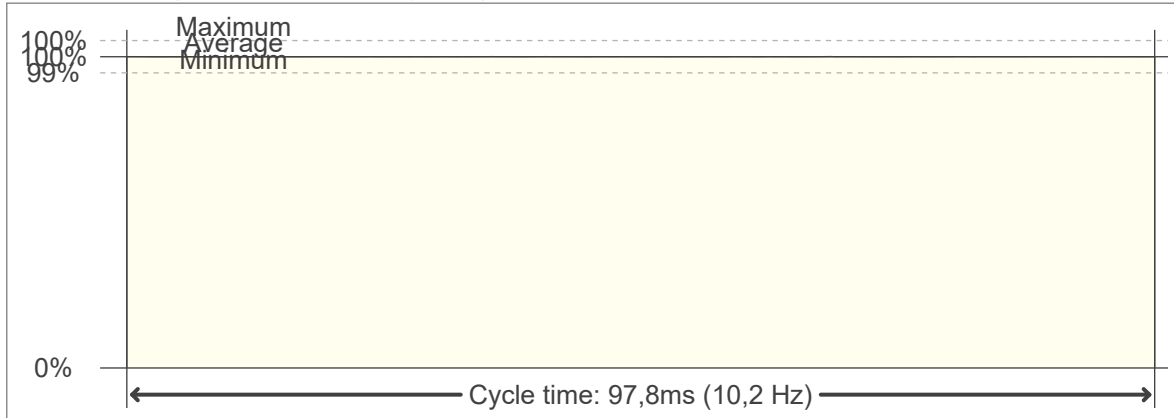

Flicker FFT (frequency scope of flicker curve)

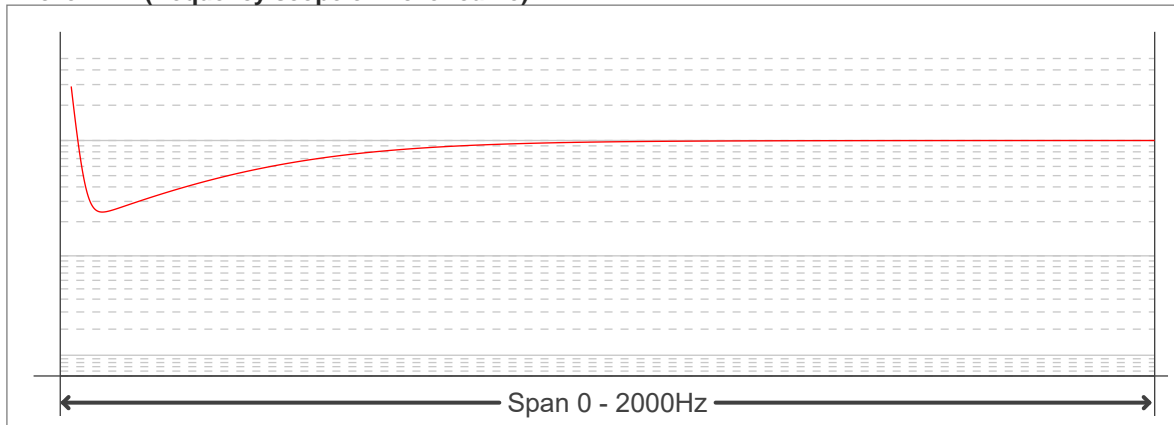

Flicker results:

Flicker frequency:		10,22 Hz	
Flicker index:	0	JA8/10 40Hz	0,04 %
Flicker percentage:	0,08 %	JA8/10 90Hz	0,05 %
SVM: (Visual flicker)	0	JA8/10 200Hz	0,06 %
PstLM	0,07	JA8/10 400Hz	0,07 %
Mp	0,02	JA8/10 1000Hz	0,07 %

Flicker conditions:

Sample rate:	20000 samples/second
--------------	----------------------