

Application

- For LED module with a forward voltage of 50-300Vdc
- Plug-in Lithium Iron Phosphate battery
- 4 years guarantee electronic
- 2 years guarantee battery
- Self-Test series
- Maintained/Non-maintained operation
- Automatic shutdown of output if LED load is out of range
- Constant power output, output current self-adjustable
- Electronic charge system
- Deep discharge protection
- Short-circuit-proof battery connection
- Open-circuit-proof
- Polarity reversal protection for battery



Technical Data

Rated supply voltage	220-240VAC
Mains frequency	50/60Hz
Mains input current, min	18mA
Mains input current, max	30mA
Input power in mains operation, min	2.8W
Input power in mains operation, max	3.5W
Power factor	≥0.5
Battery charge time	16h
Ambient temperature t_a	0-55°C
Max. Casing temperature t_c	75°C
IP rating	IP20
In-rush current	3.5A
Mains surge capability (between L – N)	1KV
Maximum withstand voltage	2KV+4U
Withstand time	60S
Mains voltage changeover threshold	140V-180V

1.All specifications are typical on the 230VAC unless otherwise stated.

2.The emergency function test must be performed when a battery is fully charged for 16 hours.



Battery Discharge & Charge Specification

Parameter	Min.	Typ.	Max.	Note
Battery discharge current	700mA	-	800mA	
Output voltage	50Vdc	-	300Vdc	* EEC15H EM 5W
Output constant current	9mA	-	75mA	* Measured at 6.4V input from batteries
Emergency power	4.6W	-	5.2W	

Item Code	Batteries	Emergency Power	Emergency Duration	Charge Current	Charge Time
EEC15H-ST	6.4V/3000mAhLiFePO4 battery	5W	3h	200mA±10%	16h

Note: All specifications are typical at 25°C unless otherwise stated.

Service Life

Average life-time 50,000 hours under rated conditions with a failure rate of less than 10% for the emergency converter as rated power. Average failure rate of 0.2% per 1000 operating hours.

Compliance

Safety Category	Countries	Standard
CE	Europe	EN61347-1, EN61347-2-7

EMC Category	Countries	Standard
EMI	Europe	EN 55015

EMS	Europe	EN 61000-3-2, EN 61000-3-3, EN 61547
-----	--------	--------------------------------------

Safety Category	Countries	Standard
-----------------	-----------	----------

AS	Australia	AS/NZS 61347-1/ AS/NZS 61347-2-7
----	-----------	----------------------------------

EMC Category	Countries	Standard
--------------	-----------	----------

C-TICK(EMC)	Australia	AS/NZS CISPR 15
-------------	-----------	-----------------

Rohs Compliance

Our products comply with the European Directive 2011/65/EU, calling for the elimination of lead and other hazardous substances from electronic products.

Mechanical Outline

unit:mm

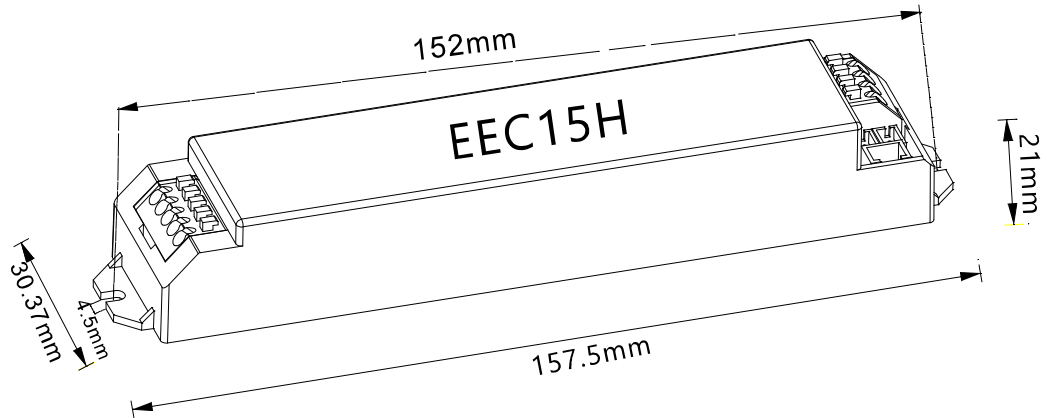

Wiring Diagram

The maximum no-load voltage of the drive is 300V

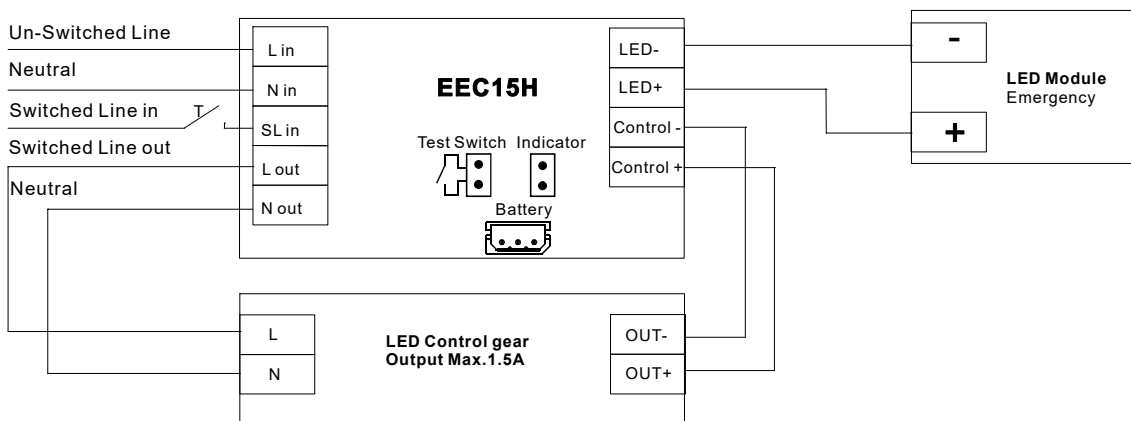

With the following cases, the indicator will be off

1. Mains power off, the light goes into emergency mode
2. Battery is disconnect when mains power on
3. Battery be connected again after disconnected when mains power on
(Attention: In that case, please re-set the AC mains power)
4. The applicable Led driver should be isolated ,and max. voltage can not over 300V, max. current can not over 1.5A.
5. When the SLin is connected, the LED light is under maintenance,
When SLin is disconnected, the LED lights are in a state of no maintenance.

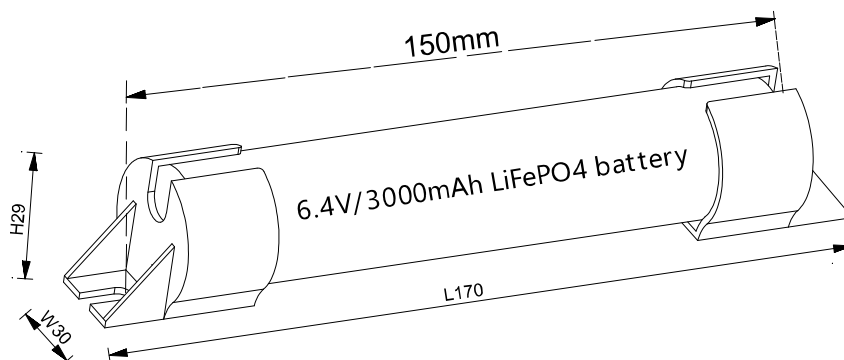
Battery Mechanical Outline

Battery

- High-temperature grade battery cells
- 6.4V LiFePO4 battery
- Male/female socket for simple connection

LiFePO4 Battery

Case temperature range to ensure 4 years design life	0°C to +60°C
Battery voltage	3.2V per cell
Capacity 18650 /26650	3000mAh

Notice: Storage condition

- The minimum charging environment temperature of the battery is 5°C , to ensure that the battery can be charged to the nominal capacity
- Batteries should be stored within the specified temperature range in low humidity conditions.
Optimal storage conditions are:
 - Temperature: -20°C to +40°C
 - Humidity: 45% - 85%
- Avoid atmosphere with corrosive gas
- It is recommended to disconnect the battery before storage or delivery
- Battery should be charged once in three mouths in order to keeping it in initial performance

Important

It is recommended that the unit is installed by a competent person ensuring the installation complies with the necessary standards.

The company accept no responsibility for incorrect installation, incorrect operation or improper maintenance.
After installation of the fitting, the battery must be charged for 16 hours for duration test.

Status Indication Green LED

- A green LED indicates that charging current is flowing into the battery
- Plug connection 1

Test Switch

- For connection to the emergency lighting unit
- For checking the device function
- Plug connection



Testing/Commissioning(self test)

Functionality of the test switch

- 1) A short press (>1s) on the button start a function test lasting 5 seconds (The battery's capacity should be more than 5%=charging 30mins)
- 2) Holding down the button(>10s) resets the timer(System-resets)

Functional test

The 5 second long, each 7 days' function test serves to check the functionality of the emergency unit, the batteries and LED module.

Notice.

-If a mains supply failure occurs whilst a functional test is in progress, the test shall be postponed and the system shall enter emergency operation. Following restoration of the mains supply, a postponed functional test shall re-commence automatically as soon as conditions permit.

Duration test(EN-3hrs)

- Initial duration test: The test will be carried out exactly 24hours later after the initial installation.
- Half year duration test: The test will be carried out on each 180-182days.

Notice.

- A duration test shall only be started when the battery supply is fully charge if a mains supply failure occurs whilst a duration test is in progress, the test shall be postponed and the system shall enter emergency operation. Following restoration of the mains supply, a postponed duration test shall re-commence automatically when the battery supply is fully re-charge
- The indicator will be slow flashing Green within 5 days if the duration test be carried out successfully.

Indicator LED System status is locally by a bi-color indicator LED.

LED Indication	Status	Description
Permanent Green	Standby , System OK	Mains Operation, battery is charged
Fast flashing Green (0.25s on 0.25s off)	Function test underway	Function test underway
Slow flashing Green (1s on 1s off)	Duration test underway	Duration test underway
Permanent Red	Lamp failure	Open Circuit or Short circuit or LED failure
Fast flashing Red (0.25s on 0.25s off)	Battery capacity failure	Battery failed duration test
Slow flashing Red (1s on 1s off)	Battery fault	Incorrect battery voltage or Short circuit or Open Circuit
Green and Red off	Battery Operation	Emergency mode:Mains disconnected or Mains failure

NOTICE

Fault status:

If an error is detected, the indicator LED switches to RED. If the error has been corrected please re-connecting the battery after the mains power off, the indicator LED immediately switches back to GREEN when mains power on.

NOTICE

Battery failed duration test:

After an exchange of the battery and holding down the button (>10S) reset the timer, the indicator LED switches to GREEN.